

## Features of the E-144 CCD Spectrometer, IV $\gamma$ -Line Configuration for September 1994

### 1 Summary of the Proposed $\gamma$ -line

This notes extends the discussion of our note of 6/18/94 to give more details of the proposed  $\gamma$ -line configuration for the Sept. 1994 run. Some material is repeated from the previous note.

Table 1: Parameters of the proposed E-144  $\gamma$ -line.

Device	Distance from IP2 (m)	$x$ edge (mm)	$y$ edge (mm)	Kick (MeV/c)
Final Focus	-23.35			
IP1	-11.41			
$\gamma$ -Convertor	1.13			
Collimator 1	11.83	$\pm 1.44$	$\pm 1.80$	
Collimator 2	23.2	$\pm 3.15$	$\pm 3.00$	
5D36 magnet	24.2			125
CCD 1	25.2	$\pm 5-31$	$\pm 8.6$	
CCD 2	26.2	$\pm 5-31$	$\pm 8.6$	
End of vacuum pipe	30.0			
$\gamma$ -calorimeter	30.8			

In brief, the elements of the proposed line are:

1. The wire convertor for Compton gammas will be placed just downstream of IP2 to minimize the effect of synchrotron radiation x-rays that scatter in the convertor. To make space for the convertor, the optical synchrotron radiation monitor will be removed and a 20' section of existing beam pipe moved downstream by 13" to make room for the wire convertor. The wire convertor and associated vacuum chamber will be provided by Princeton U.
2. A vacuum bypass will be installed around Clive's Čerenkov monitor, permitting use of that device in air during FFTB studies, and then having vacuum along the  $\gamma$ -line during E-144 running. Design of the bypass by B. Brugnoletti is nearly complete. It occupies 14' along the beamline.
3. Collimator 1 will be installed just downstream of the bypass. This collimator has 10" of copper, with a 10"-long tungsten insert of 0.75" outer diameter.
4. Just downstream (or even upstream) of collimator 1 there should be a spool piece of pipe about 0.5" in diameter with at least 16" free space to allow a 16" stack of lead bricks to be placed between the  $\gamma$ -line and the electron dump line. This lead must intercept the swath of synchrotron radiation emanating from the soft bends and the permanent dump magnets. The top of the lead stack must be higher than the bottom edge of the tungsten insert of collimator 1.
5. Nearly 40' of 4"-diameter vacuum pipe must be installed between collimators 1 and 2. It would be useful to have an ion pump somewhere in this section of pipe.
6. Collimator 2 will be located just upstream of the 5D36 magnet. It is similar to collimator 1, but with a larger aperture in its tungsten insert.
7. The 5D36 analysis magnet will have a vacuum pipe running through it. This pipe is existing, but will need new flanges. We propose to standardize on 6" Conflat flanges throughout the  $\gamma$ -line.
8. A 10'-long 'snout' of 7/16" vacuum pipe will be attached to the downstream flange of the vacuum chamber of the 5D36. This snout will extend through the center of the Sept. '94 version of the CCD spectrometer so the synchrotron radiation that passes through the apertures of the collimators does not hit any material close to the CCD's. [For the Feb. '95 run the CCD spectrometer will be in vacuum, and we propose to attach the snout to the downstream end of the CCD vacuum box at that time.]
9. The vacuum line should extend another 3 m, ending just upstream of the  $\gamma$ -calorimeter. This last 10' section can be of 4"-diameter pipe.

A CAD drawing of a preliminary version of the  $\gamma$ -line is appended to this note. We now give greater detail about the beamline components.

## 2 Compton Converter

Although the Compton converter was originally conceived as being placed just upstream of the 5D36 analysis magnet, the calculations reported in our note of 6/18/94 indicate that backgrounds from scattering of synchrotron radiation in the converter would be too severe in this location. But if the converter is upstream of collimator 1 the CCD's should be well protected from the scatters.

The Compton converter will consist of one or two fine wires (plus a foil for initial tests) mounted on a fork cantilevered from an MDC SBLM-275-4 bellows-sealed linear-motion feedthrough, as shown in Fig. 1. The feedthrough will be actuated by an Aerotech ATS50 linear stage with stepper motor (used in the May '94 CCD test). This stage will provide 2" travel with micron resolution.

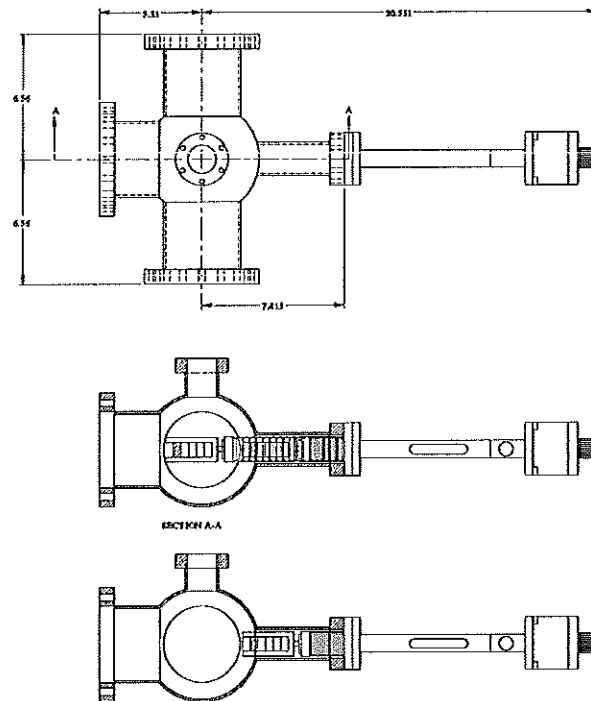

Figure 1: Sketch of the proposed Compton converter. It occupies the same length along the  $\gamma$ -line as the present optical synchrotron radiation monitor.

At the proposed position of the Compton converter the horizontal extent of the  $\gamma$ -line is less than  $\pm 0.75''$ , as set by the pole-tip gap of the dump magnets. The active region of the converter will be only 1" wide, so all material can be retracted completely from the active width of the  $\gamma$ -line.

### 3 Collimators

The two copper/tungsten collimators as designed to shield the CCD's from direct synchrotron radiation, as well as that from scattering off the aperture of the first collimator. Some relevant rays are sketched in Fig. 2.

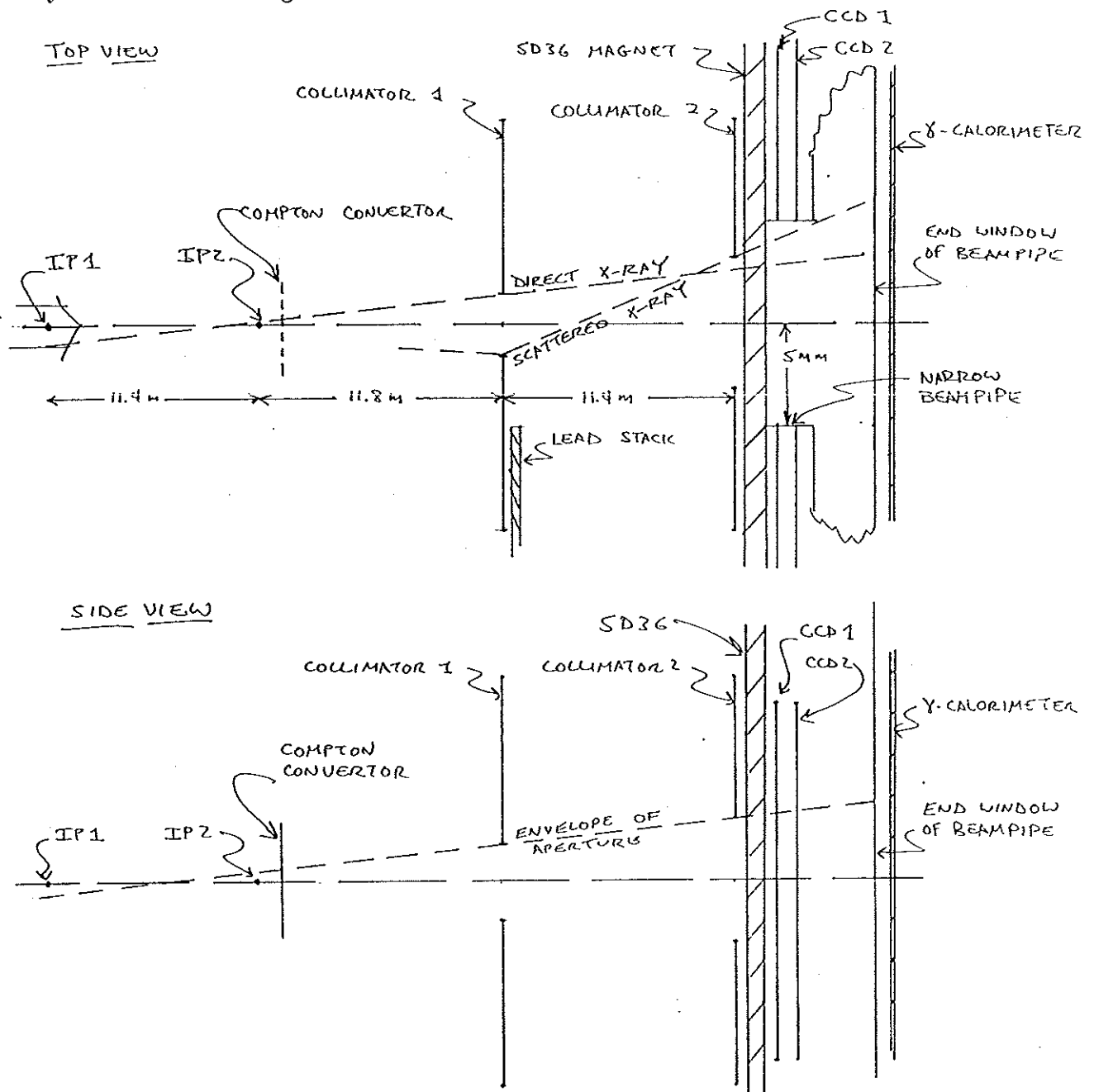

Figure 2: Top and side views of the  $\gamma$ -line showing proposed collimator apertures, and the scenarios that determine those apertures.

## 4 Estimate of Synchrotron Radiation Flux

We recall the basic ingredient of the synchrotron-radiation-flux calculations presented in our note of 6/18/94

We have used the formulae of sec. 5.1 of SLAC-121 by M. Sands to estimate the flux of synchrotron radiation from various FFTB magnets relevant to E-144. The magnet parameters are listed in Table 2 and the results are shown in Fig. 3 for a bunch of  $10^{10}$  electrons. In calculating the radiation from the final focus quadrupoles, we supposed that the electron beam was round and had  $\sigma_x = \sigma_y = 1$  mm.

Table 2: Parameters of FFTB magnets considered in the synchrotron radiation calculations.

Magnet	$B$ (Gauss)	$L$ (m)	$E_{\text{critical}}$ (keV)
Alnico dump magnet	4500	1	662
Soft bends	500	2	74
Very soft bends	60	2	8.9
Earth's magnetic field	0.33	50	0.049
Final Focus quadrupoles	9500 G/26 mm	2	$\approx 75$

The alnico dump magnet has the hardest spectrum, but since all of this radiation is at angles of at least 0.5 mrad to the E-144  $\gamma$ -beam this should be maskable. All of the other magnets listed yield some radiation within 50  $\mu$ rad of the  $\gamma$ -beam, which radiation cannot be masked, but must be survived. The Final Focus quadrupoles appear to be the biggest source of this class of radiation.

## 5 Estimate of the Rate of Doubly Scattered Synchrotron Radiation

If the two collimators are well aligned, the principal source of background in the CCD's will be synchrotron radiation that has scattered two or more times. We make a rough estimate of the rate of doubly scattered radiation, supposing that any x-ray that hits within 100  $\mu$ m of the edge of the aperture of a collimator is scattered rather than absorbed. H. de Staebler advises us that the effective thickness over which scatters occur is closer to 10  $\mu$ m than 100, so perhaps our estimate is 'conservative.'

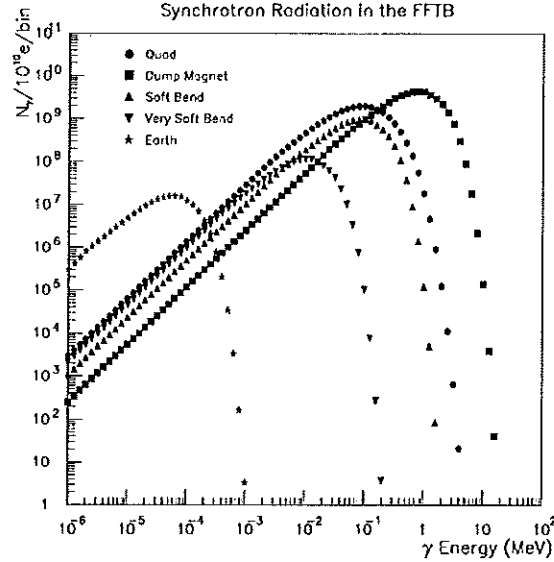

Figure 3: Calculated flux of synchrotron radiation from various FFTB magnets for  $10^{10}$  electrons. Each point represents the sum over a bin in energy where  $E_{\max} = 1.26E_{\min}$ .

Under the above assumption, about 1% of the radiation from the soft bends, and 0.1% of the radiation from the Final Focus quads will scatter off the aperture of collimator 1. From Fig. 3 we find that this implies that about  $10^7$  10-keV x-rays, and about  $10^8$  1-MeV x-rays scatter off collimator 1 per pulse of  $10^{10}$  electrons.

The solid angle of a  $100\text{-}\mu\text{m}$  band around the aperture of collimator 2 with respect to collimator 1 is about  $10^{-9}$  of  $4\pi$  using the parameters from Table 1. The solid angle of CCD 1 with respect to collimator 2 is about  $10^{-5}$  of  $4\pi$ .

For 10-keV x-rays, the scattering is essentially isotropic, so the probability of a double scatter that passes through CCD 1 is  $10^{-14}$ , and the rate is about  $10^{-7}$  per pulse of  $10^{10}$  electrons.

The active region of a CCD is about  $5 \times 10^{-3}$  gm/cm<sup>2</sup> thick, which is about the same as the absorption length of a 10-keV x-ray in silicon ( $10^{-2}$  gm/cm<sup>2</sup>). Hence we estimate that  $10^{-7}$  10-keV x-rays can double scatter and be absorbed by CCD 1 per pulses.

For 1-MeV x-rays the scattering is forward peaked. We approximate the forward scattering cross section as 10 times isotropic. In this case the probability of a double scatter of a 1-MeV x-ray is about  $10^{-12}$ , and so about  $10^{-4}$  of these x-rays pass through CCD1 per pulse. But the absorption length for 1-MeV x-rays is about 10 gm/cm<sup>2</sup>, so only one in 1000 of these x-rays would be absorbed to give a background hit. That is, the background rate due to 1-MeV x-rays is also about  $10^{-7}$  per pulse.

Our estimate is no doubt low in that the x-rays can multiple scatter off the beampipe

and elsewhere. We hope that the safety margin of several orders of magnitude is sufficient.

## 6 Location of Collimator 2

In the above calculation, the rate of double scatters would be reduced by a factor 1/4 if collimator 2 were placed midway between collimator 1 and CCD 1. However, in this case collimator 2 cuts away about half the acceptance for  $e^+e^-$  pairs. In view of the apparently large safety factor against doubly scattered x-rays we proposed to keep collimator 2 just upstream of the 5D36 magnet.

## 7 Vertical Aperture of the Collimators

In previous discussions of the acceptance of the CCD spectrometer inside the FFTB tunnel we had neglected to note that only the inner half of the vertical extent of the CCD's is useful. [Recall that the 17-mm-high EEV CCD's were chosen in part to match the desired vertical aperture for a CCD spectrometer located outside the tunnel.]

Therefore it is reasonable to reduce the vertical apertures of the collimators, as listed in Table 1. This has the advantage that the thickness of the walls of the 0.75"-diameter tungsten inserts are great enough to be mechanically viable.

## 8 Vacuum Pipe Downstream of the 5D36 Magnet

About 10% of the synchrotron radiation from the soft bends will pass through the collimators and eventually hit the exit window of the vacuum system. As discussed in our note of 6/18/94, if this window is near the 5D36 magnet the scattering of x-rays in the window and air beyond the window would cause unacceptable backgrounds in the CCD's.

Therefore we propose to attach a 10' section of narrow vacuum pipe (7/16" diameter) downstream of the 5D36 magnet. The upstream end of this pipe should have a thin window that makes the transition from a 6" Conflat flange.

There remains the problem of protecting the CCD's from the  $\sim 10^9$  x-rays in the range 10-1000 keV that reach the end of the vacuum pipe. Some of these will scatter by  $180^\circ$  off the end window, and then scatter off the vacuum pipe close to the CCD's to cause background hits. To minimize this effect, the vacuum pipe should extend downstream as far as possible, ending just upstream of the  $\gamma$ -calorimeter. The distance from CCD 2 to the end window would then be about 3.8 m.

We make a rough estimate of the rate of this double-scattering background process. The CCD's are approximately  $2 \times 2$  cm<sup>2</sup> in area. So the CCD's subtend roughly 1 steradian for x-rays whose second scatter is on the wall of the vacuum pipe within  $\pm 2$  cm of the CCD's. This section of pipe has solid angle  $d\Omega = 2\pi\theta d\theta$  relative to the exit window of the vacuum pipe. The beampipe near the CCD's has radius about 6 mm, so the angle of this section of pipe relative to the exit window is  $\theta = 6/3800 = 1.6 \times 10^{-3}$ . The interval  $d\theta$  is given by  $6/3800 - 6/3840 = 1.6 \times 10^{-5}$ , so  $d\Omega = 1.6 \times 10^{-7}$ . For isotropic scattering, the double

scattering probability is then  $d\Omega/4\pi \cdot 1/4\pi \approx 10^{-9}$ . The rate of background hits is then roughly one per pulse of  $10^{10}$  electrons.

Of course, double scatters will occur outside the 4-cm-long section of beampipe considered above. But the solid angle of the CCD is reduced for these scatters, and the x-rays pass through the pipe at a low angle after the second scatter and are attenuated somewhat. So we believe our calculation represents the dominant effect.

Thus it appears that even with the vacuum pipe as long as possible, the major source of background hits in the CCD's will be associated with backscatters off the exit window.



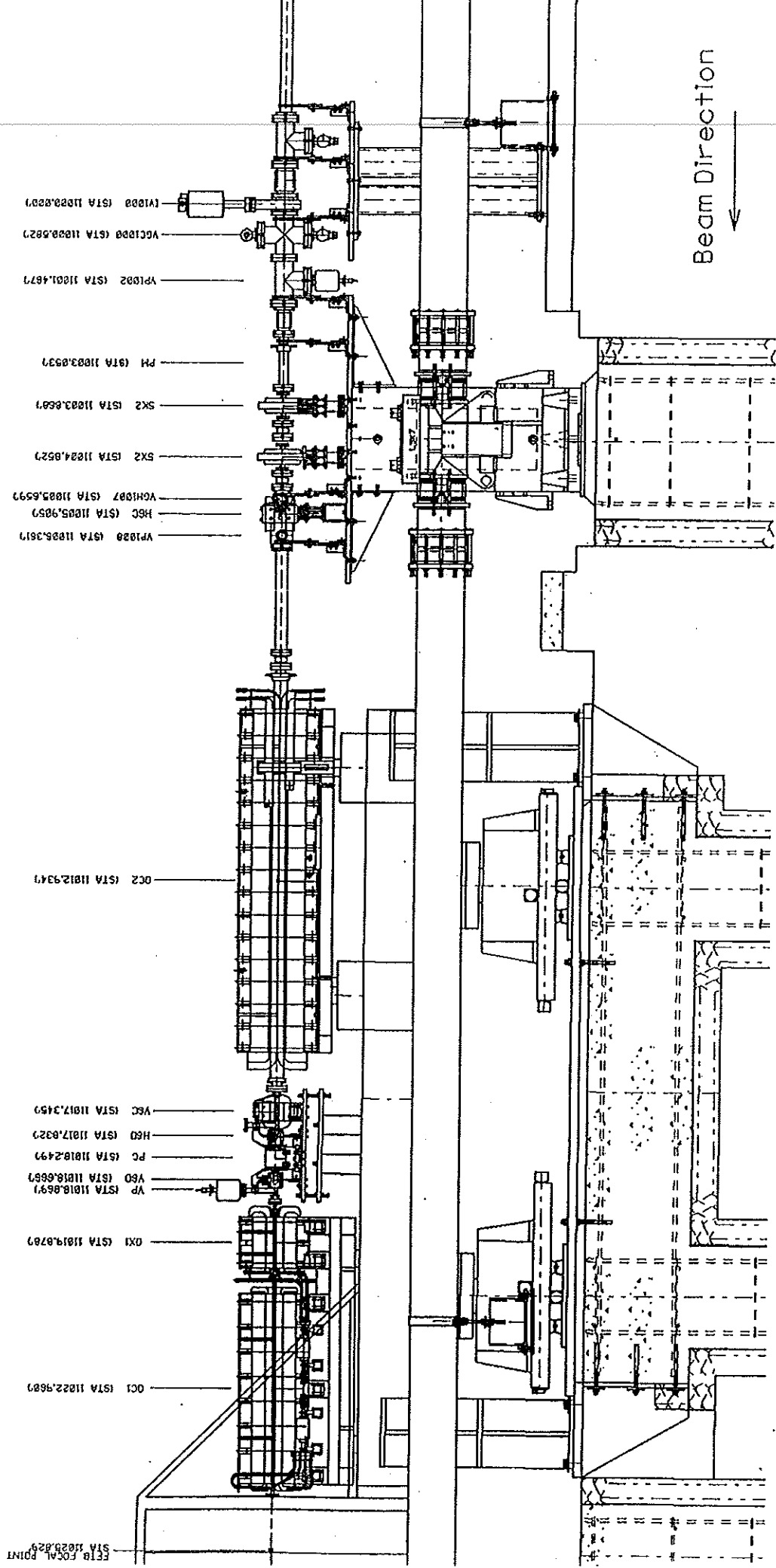

FFTB  
FINAU  
FOCUS

FFTB FOCUS POINT  
STA 11029.3229

V56A (STA 11026.6617)

ORSAY (STA 11027.5357)

V56B (STA 11029.1917)

V1029 (STA 11029.3229)

OP1A STA 11030.6067

OP1B STA 11032.6507

OP2A STA 11034.4437

OP2B STA 11036.3367

OP3A STA 11039.3967

OP3B STA 11043.3367

OP4 STA 11047.2727

H7C STA 11049.8017

V7C STA 11051.1317

OP5 STA 11053.0347

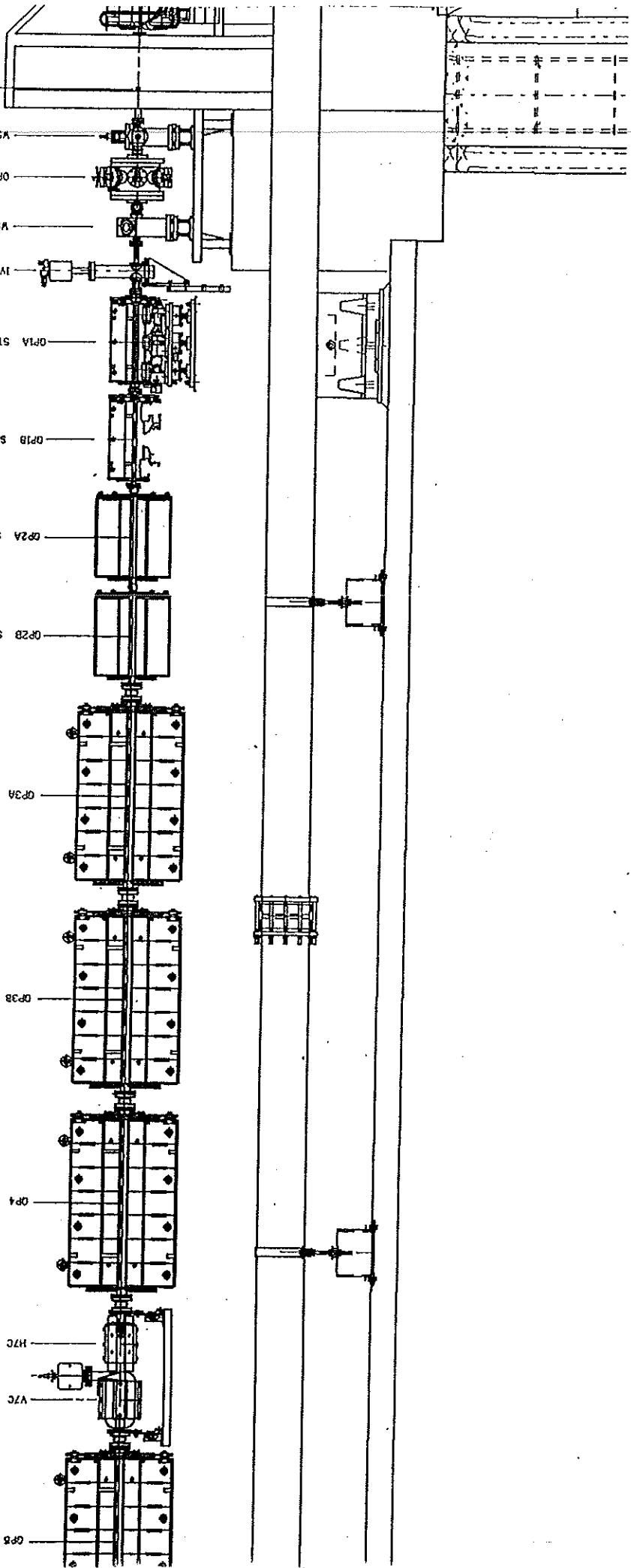

IP4

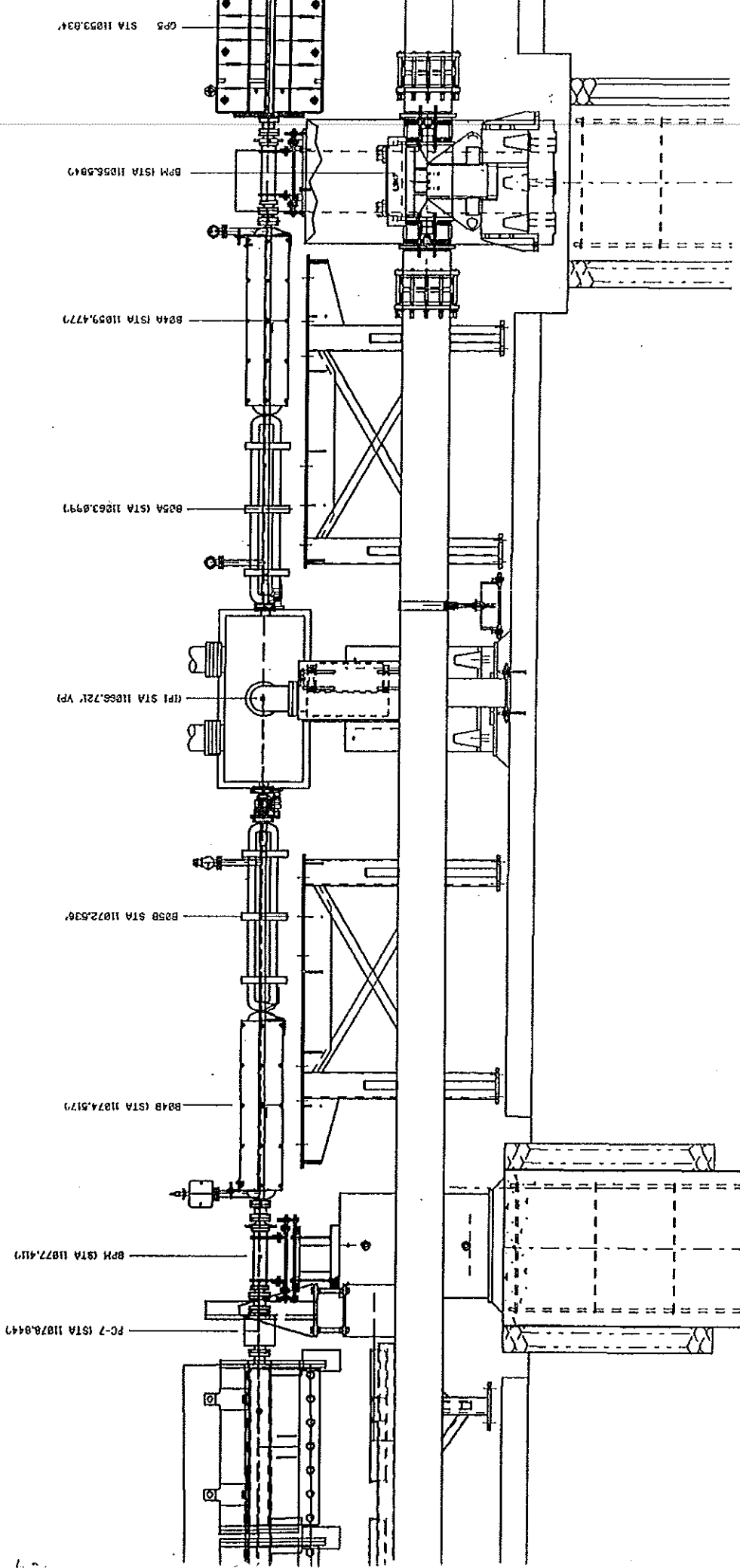

10,000  
REPRODUCED

FROM VIEW OF  
TYPE 2 COARD  
HAS BEEN REDUCED  
BY 10,000'

CALDRIMETER  
STA 1894.1433

CALDRIMETER  
(STA 1182.984)

VP1104 (STA 1182.658)

IP2 (STA 1184.146)

IP2

(107.84)'

CARBON  
WIRE

Beam Direction  
↓

STA 1182.984 STA 1184.146

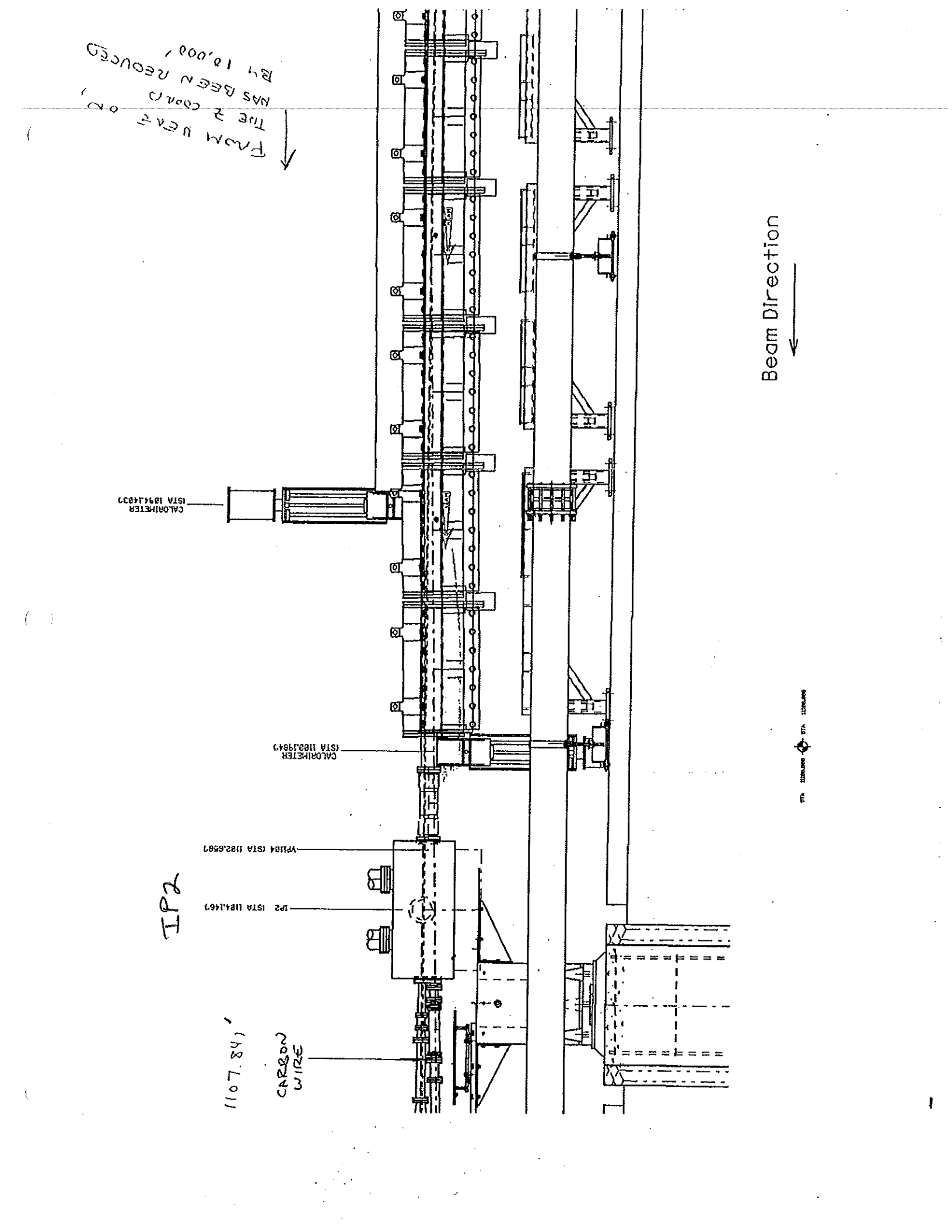

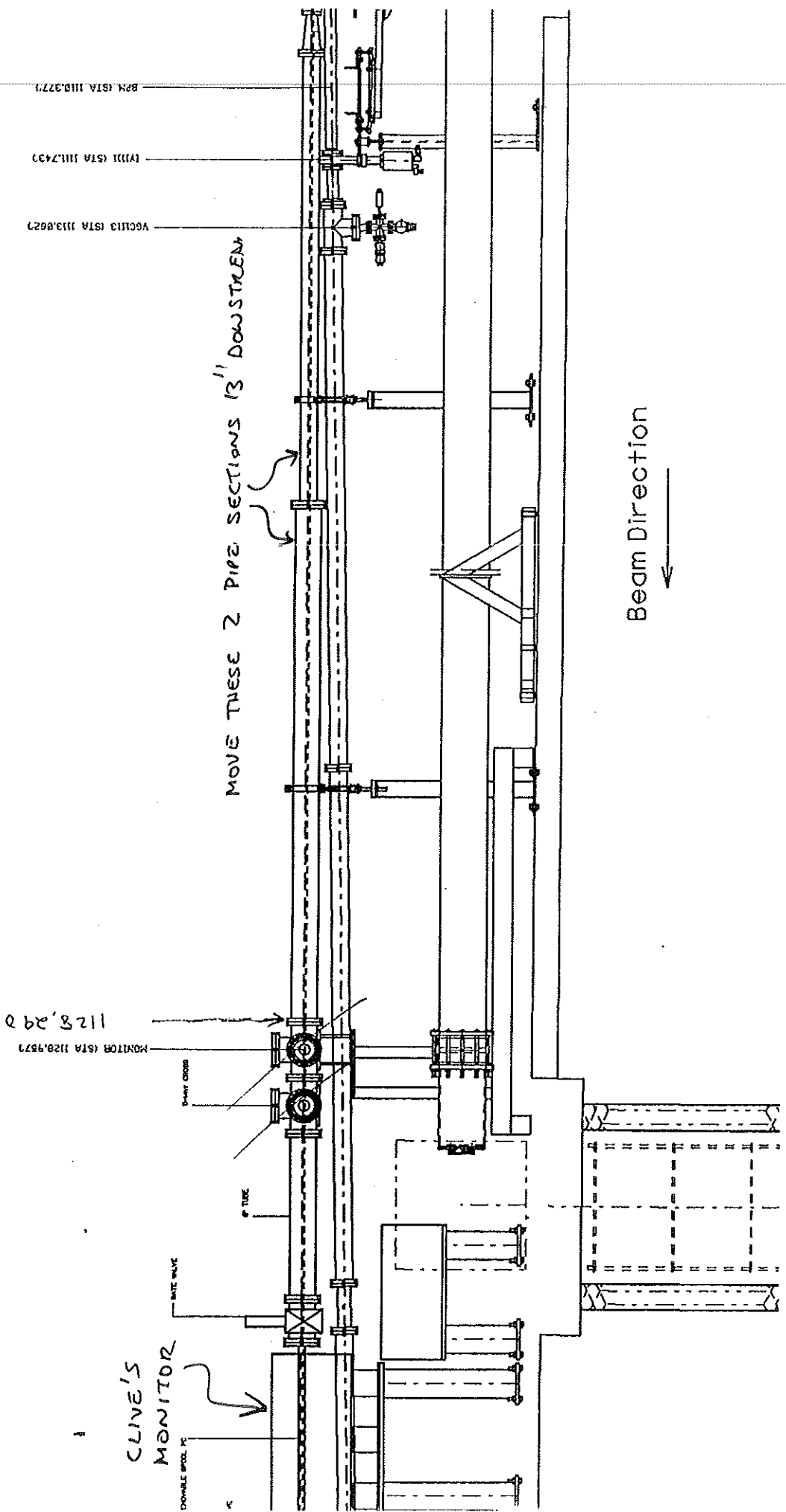

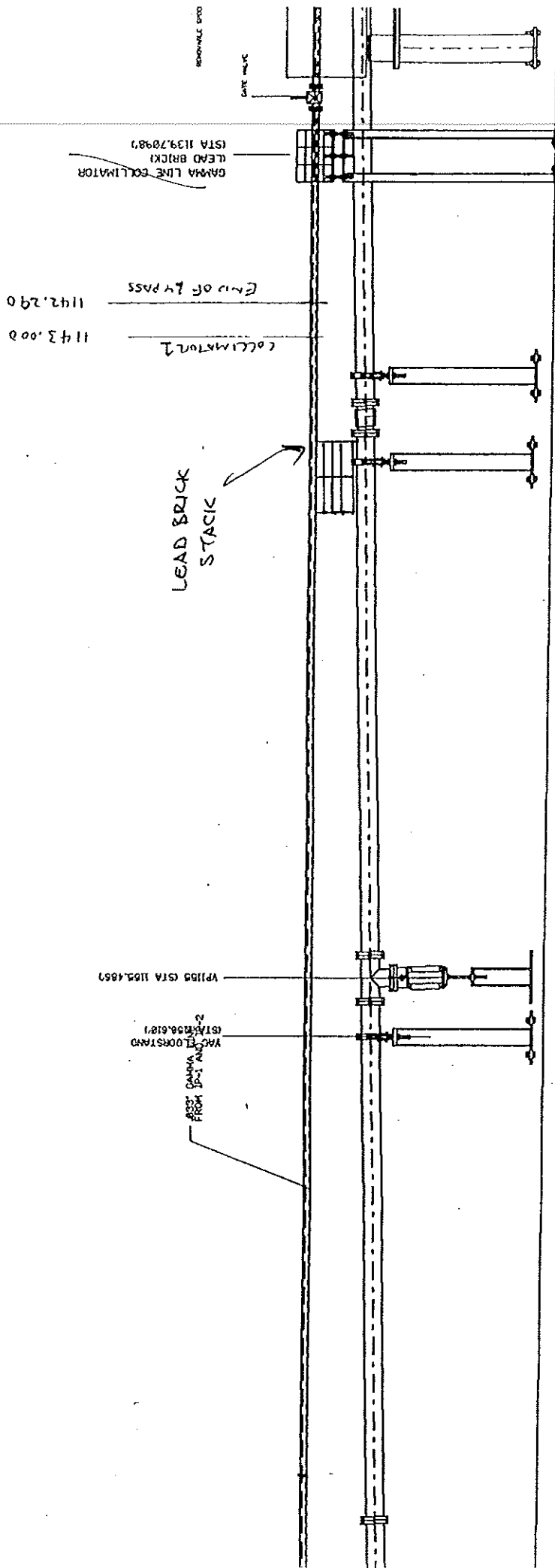

1180.26'

COLLIMATOR 2

1183.576'

5 D36

1186.909

1190.242

(STA 1185.243)

(STA 1193.7976)

CCD SPECTROMETER  
CCD 1

CCD 2

LEAD STACK FOR PC-8

4.250

ANALYSIS MAGNET  
(SUSS)

K LINE FROM MACHINE SLOPE OF 27.2° PROJECTED AS IF FOR COMPATIBILITY WITH MECHANICAL INSTALLATION B-65D

G LINE (BANK LINE FROM FFTB FOCAL POINT)

CONVERTER CD

BE WINDOW

CLEAN-UP COLLIMATOR

4.813

28.44'

24.78'

Beam Direction  
↓

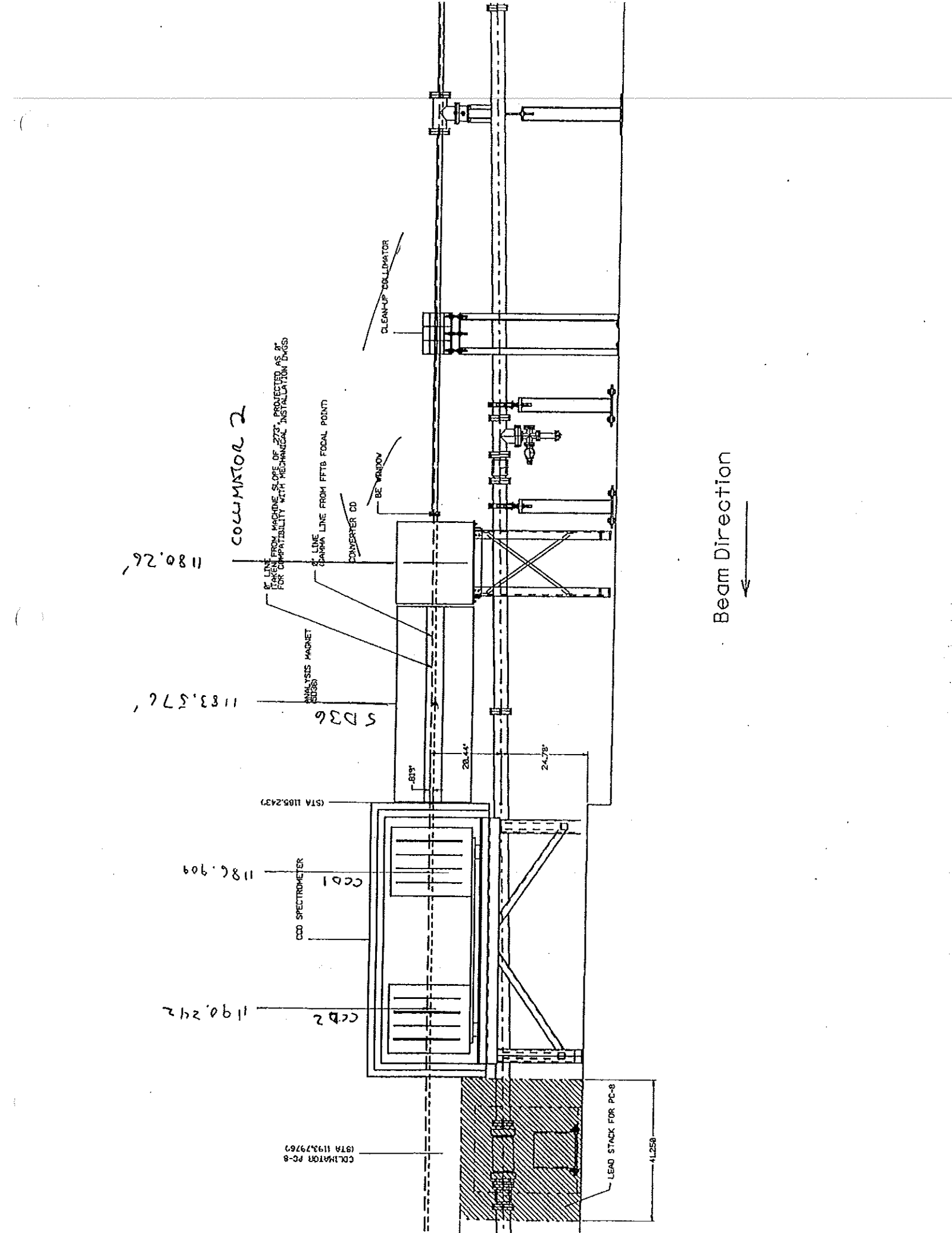

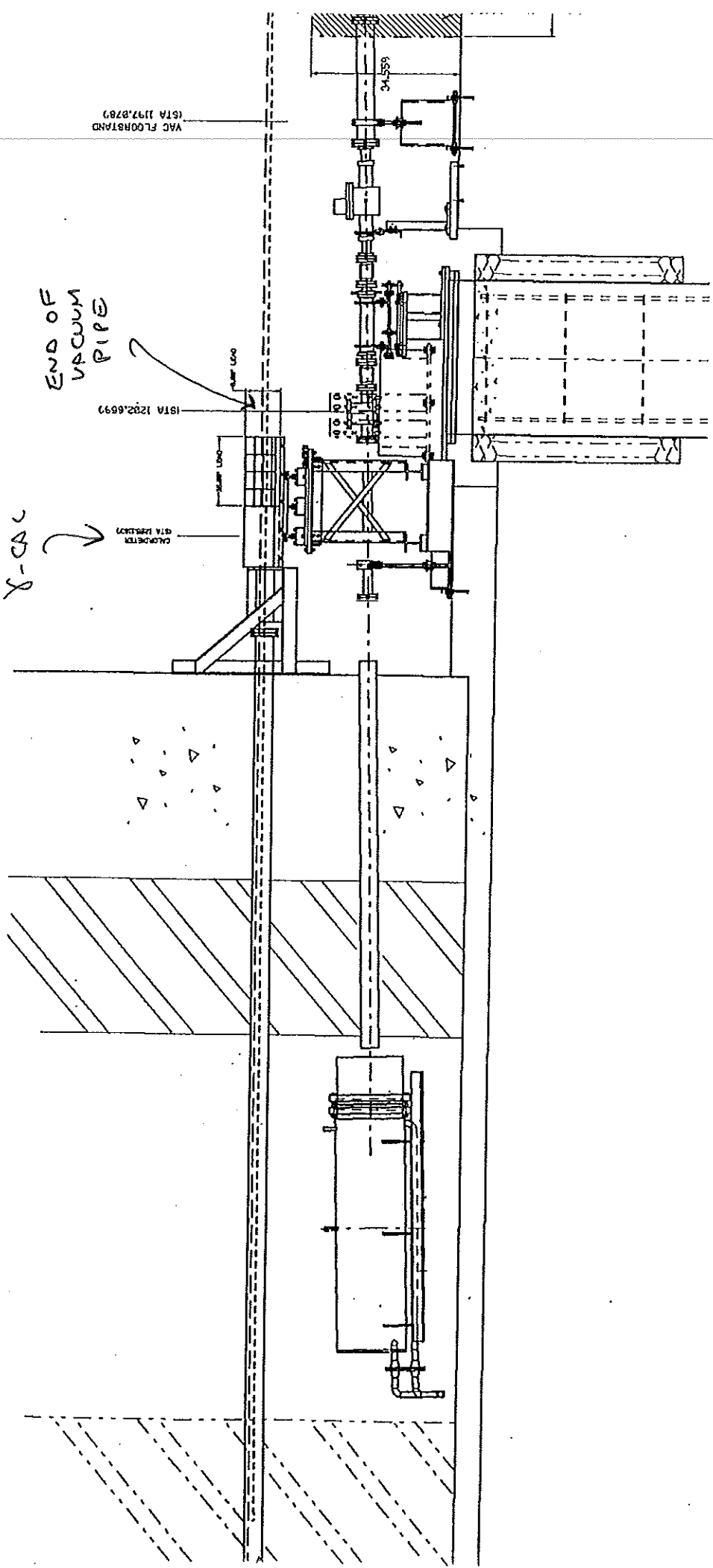

GAS-CA

END OF VACUUM PIPE

VAC FLOORSTAND (STA 1177.2783)

STA 1222.6593

GAS-CA

10.00