

High Power Hg Target Conceptual Design Review

Hg Target Interface with Solenoid

V.B. Graves

P.T. Spampinato

T.A. Gabriel

Oak Ridge National Laboratory

February 7-8, 2005

Outline

- **Target module insertion**
- **Solenoid thermal insulation**
- **Solenoid operational cycle**
- **Solenoid orientation changes**
- **Field plots**
- **Solenoid / target base support structures**

Target Module Insertion

- **Primary and secondary containment mechanically fastened (weight ~ 160 lbs)**
- **Flexible metal hoses probably already attached**
- **Can be inserted either before magnet aligned to beam or after**

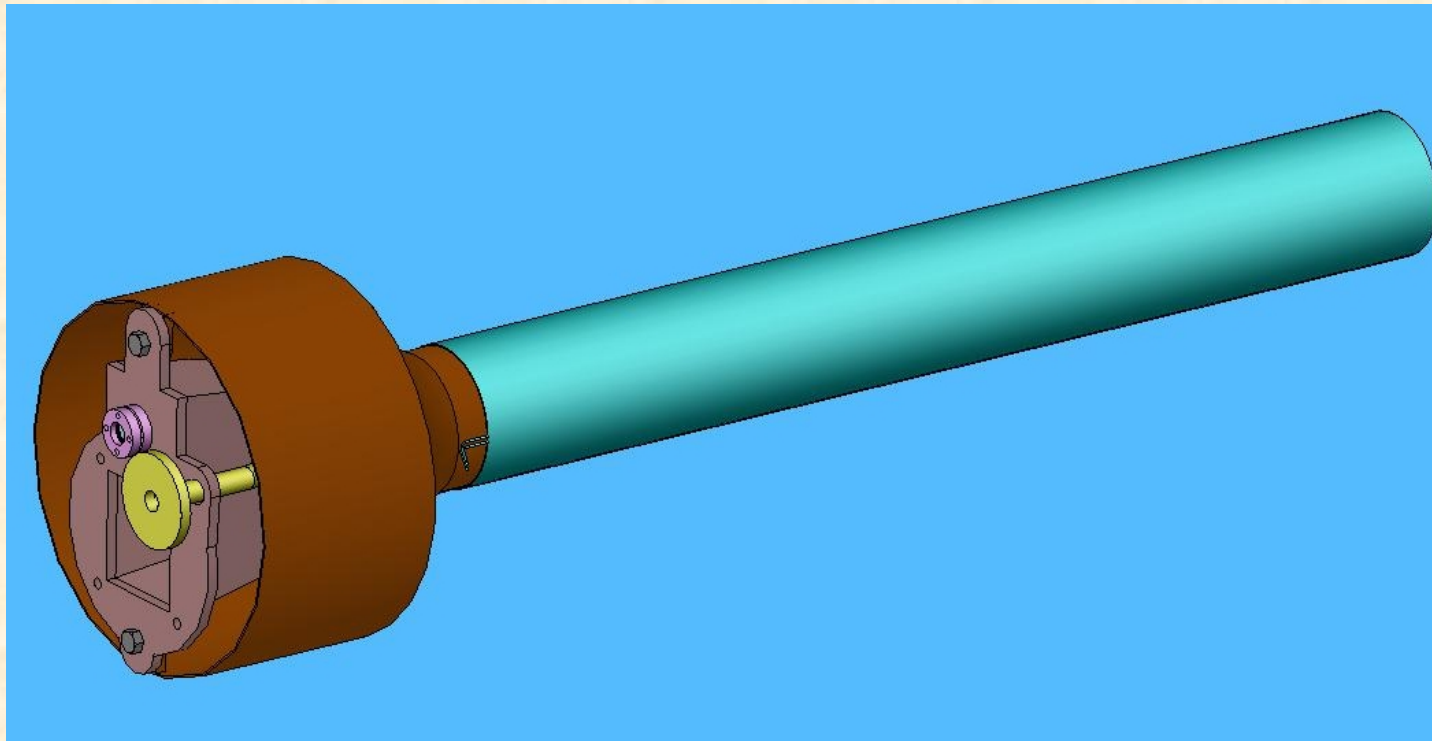

Solenoid Thermal Insulation

- **Original solenoid design incorporated insulating bore tube (G-10)**
- **Removal of G-10 tube provided more room for target module components**
- **Insulation replaced by addition of flexible foil heater (silicone or kapton) 0.007" – 0.060" thick outside the secondary tube**
- **May only need on one end of secondary containment tube**
- **Requires controllable power supply**

Magnet Operational Cycle

Parameters of Pulse Coil Precooled to 69 K and Energized at 600 V to 7200 A

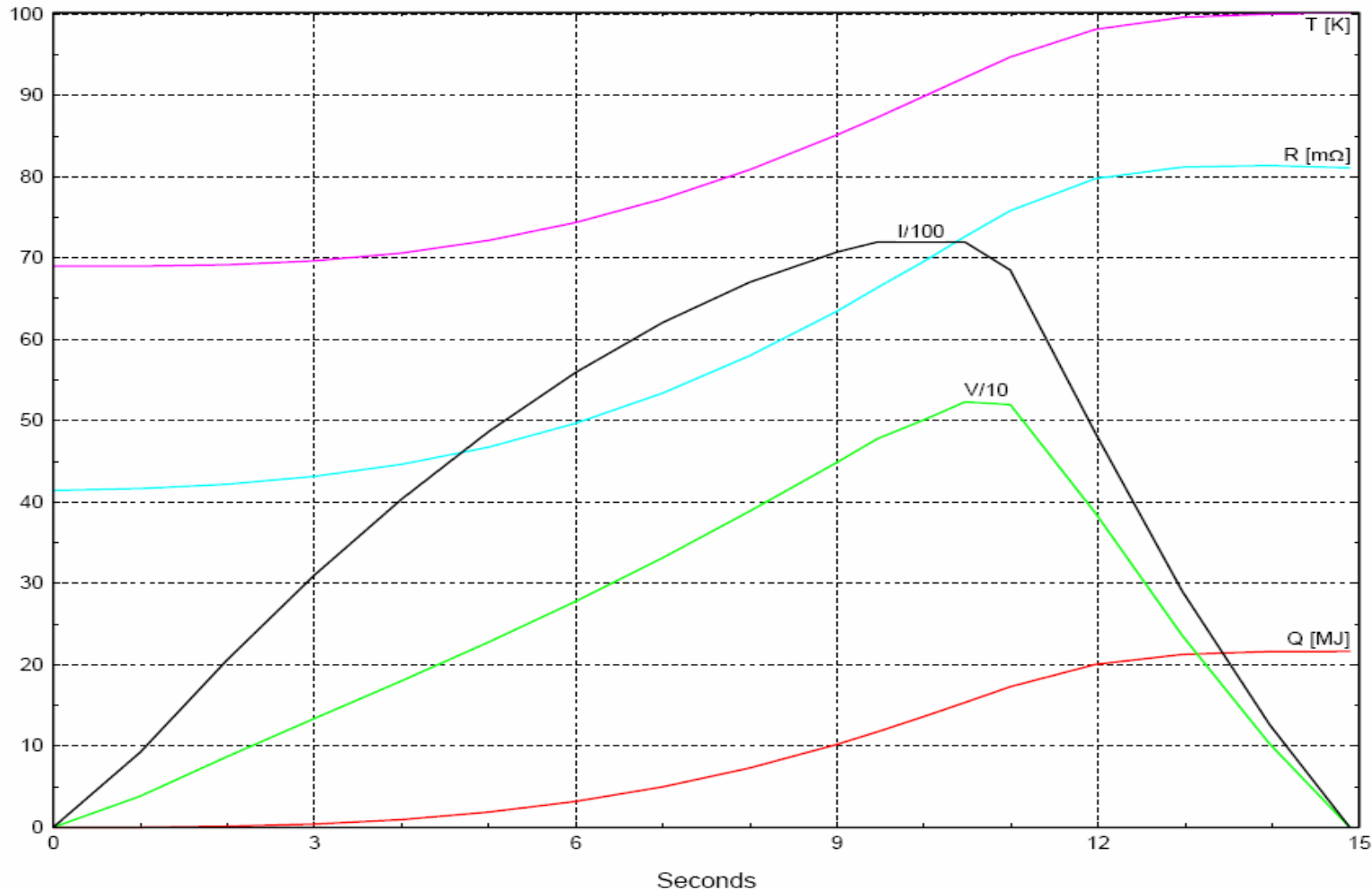

Bob Weggel's 10-14 analysis of the LN2 magnet operation

OAK RIDGE NATIONAL LABORATORY
U. S. DEPARTMENT OF ENERGY



Magnet Positional Changes During Max Field

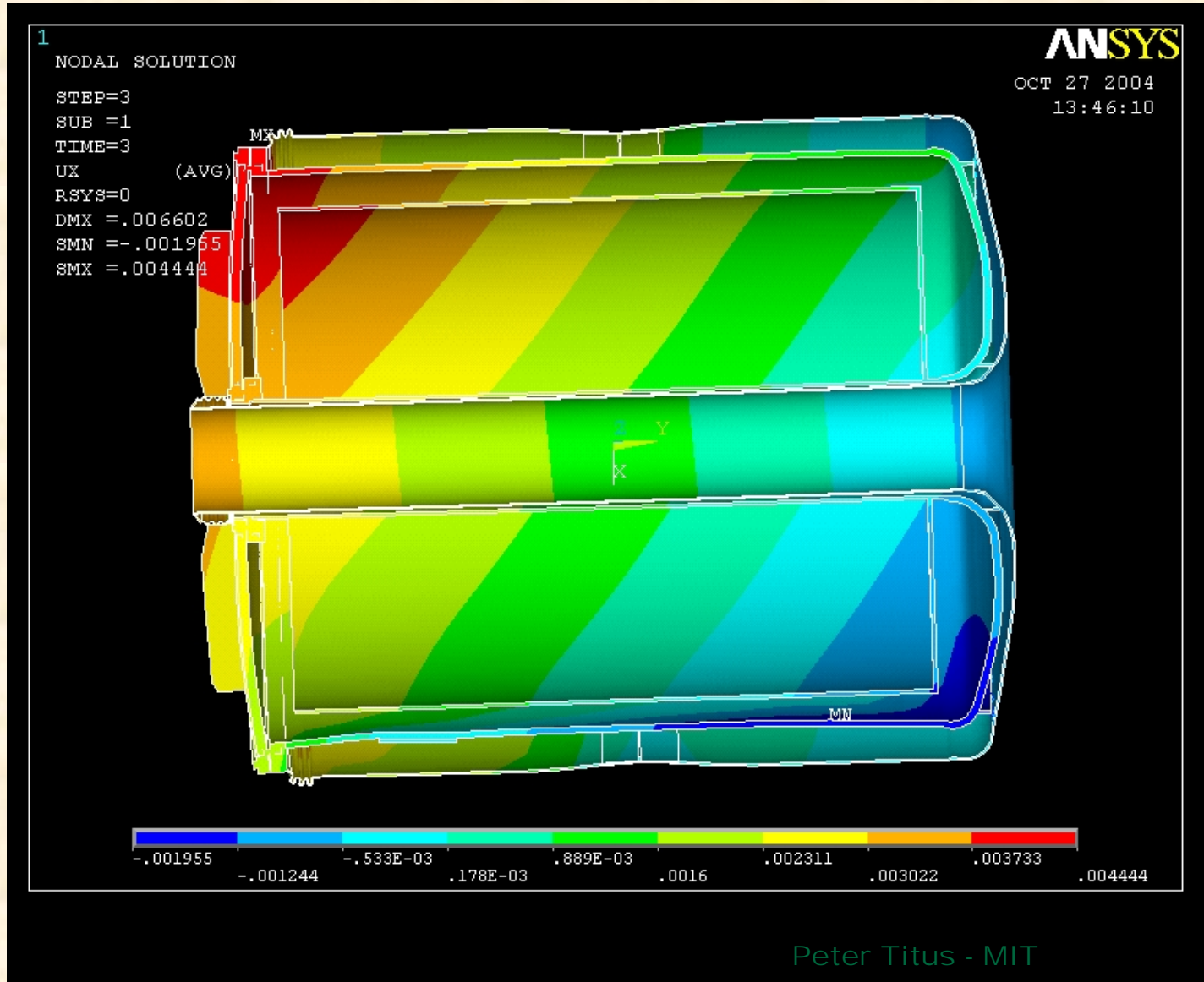

Consequences of Magnet Movement

- **Vertical movement summary**
 - Upbeam end: -3 mm
 - Downbeam end: +1.2 mm
 - Z=0 position: -0.9 mm
 - 3.5mrad tilt over assumed 1200mm length
 - Position of zero vertical movement at Z=+257mm
- **No compensation in design (nozzle position) for Z=0 movement**
- **Actual movements to be measured during solenoid testing**

Design Alternatives

- **Magnet movement must be accommodated by target system**
 - Target can float within magnet or be small enough that movement does not produce contact
- **Space constraints within target secondary containment push toward maximizing secondary diameter and floating with magnet**
 - Tilt changes accommodated by flex metal hoses

Magnet Field Plot

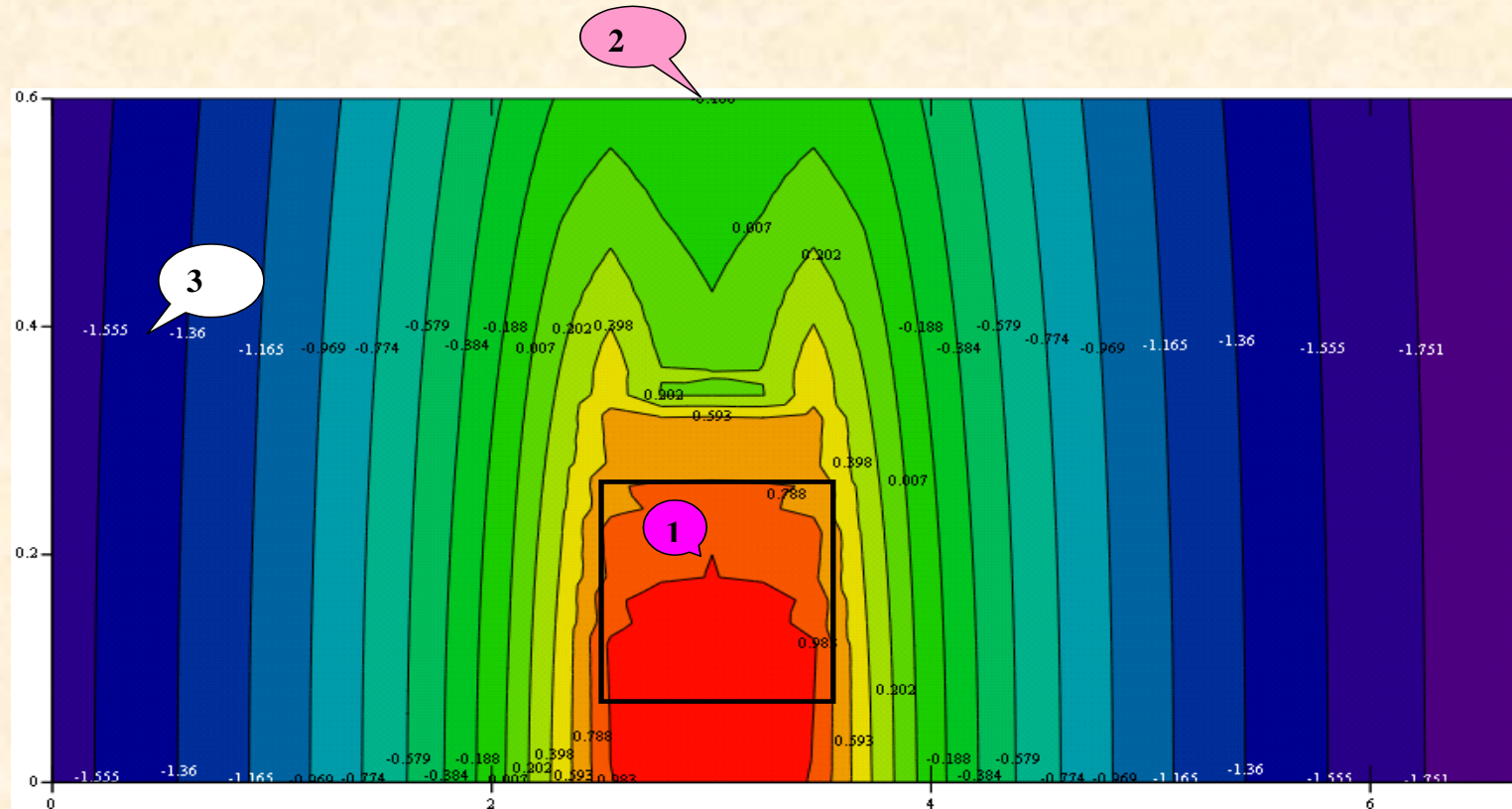

$(xyz_0, xyz_1, \log(xyz_2))$

Magnetic field distribution: the axes are in meters; the rectangle is one half of the solenoid.

- The volume within the conductor is > 9.7 T (red), > 6.1 T (orange).
- The field at $Z=0, R=0.6$ is >0.6 T, at $R=1.0$ (base support structure), $B > \sim 0.1$ T (1000 G).
- The field at $Z=-2.5, R=0.4$ (pump motor) is $0.03 < B < 0.07$ T (300-700 G).

Fields with Solenoid

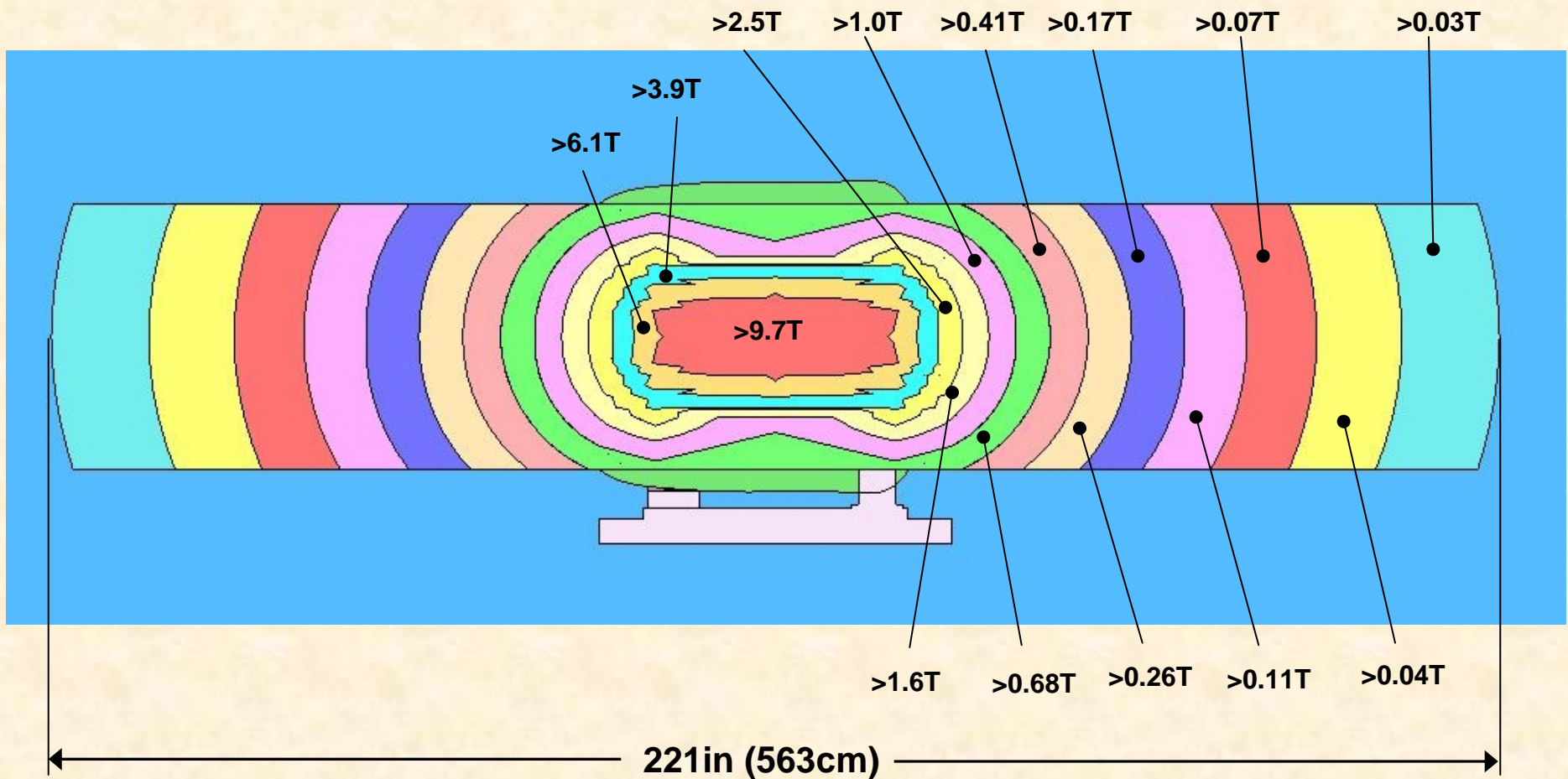

Field Near Equipment

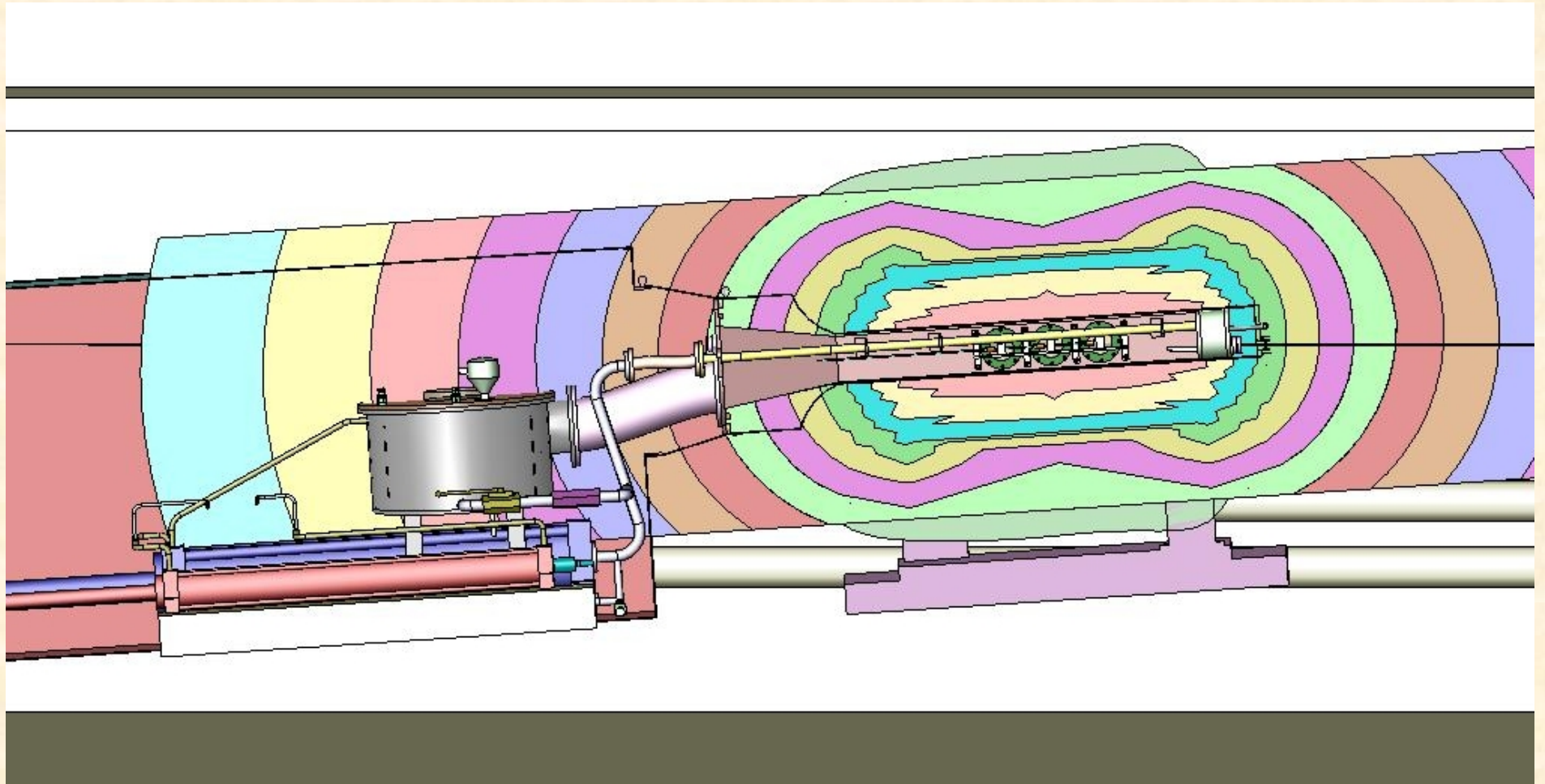

Issues

- **Position hydraulic pump to minimize field effects**
- **Max field at cylinders between 0.17T & 0.26T**
- **Need steel cover plates for magnetic shielding over cylinders?**
- **Remote valve or sensor concerns?**

Magnet & Target Base Supports

- **Flexible metal hoses somewhat decouple the target module from the delivery system**
- **Only the magnet & target module must be precisely positioned relative to beam**
 - Hg delivery system does not have to tilt or be exactly in line with magnet
 - Downbeam window on secondary containment should be oversized to accommodate delivery system misalignment
- **Base material will be carbon steel or aluminum, depending on cost**

Base Supports

- Magnet & Hg system will have independent mobility and leveling features
- Independent base supports should make equipment installation less complex

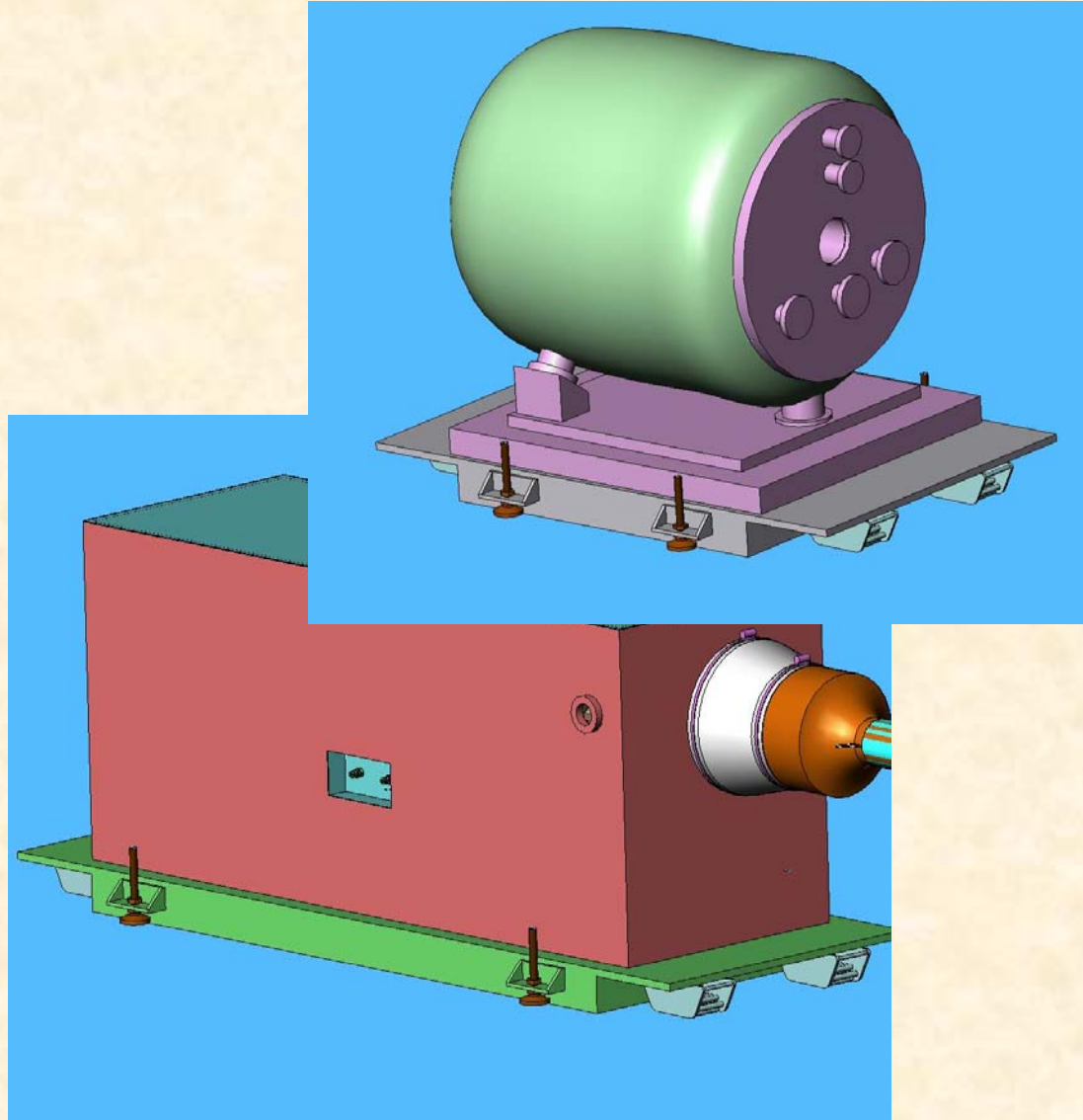

Recommendations

- **Change from a common base support to independent supports for solenoid and Hg delivery systems**
- **Both should incorporate mobility and tilt/leveling features**
- **Increase size of secondary downbeam window to accommodate Hg system misalignment**