



Journal logo

A Free Jet Hg Target Operating In a High Magnetic Field Intersecting a High Power Proton Beam

V.B. Graves^{a*}, P.T. Spampinato^a, T.A. Gabriel^a, H. Kirk^b, N. Simos^b, T. Tsang^b,
K. McDonald^c, P. Titus^d, A. Fabich^e, H. Haseroth^e, J. Lettry^c

^a*Oak Ridge National Laboratory, Oak Ridge, TN 37831, USA*

^b*Brookhaven National Laboratory, Upton, NY 11973, USA*

^c*Princeton University, Princeton, NJ 08544, USA*

^d*MIT Plasma Science and Fusion Center, Cambridge, MA 02139, USA*

^e*CERN, CH-1211 Genève 23, Switzerland*

Elsevier use only: Received date here; revised date here; accepted date here

Abstract

A proof-of-principal experiment to investigate the interaction of a proton beam, high magnetic field, and high-Z target is planned to take place at CERN in early 2007. This experiment is part of the Muon Collider Collaboration, with participants from Brookhaven National Laboratory, Princeton University, Massachusetts Institute Of Technology, European Organization for Nuclear Research-CERN, Rutherford Appleton Laboratory, and Oak Ridge National Laboratory. An unconstrained mercury jet target system that interacts with a high power (1 MW) proton beam in a high magnetic field (15 Tesla) is being designed. The Hg jet diameter is 1-cm with a velocity up to 20 m/s. A laser optical diagnostic system will be incorporated into the target design to permit observation of the dispersal of the jet resulting from interaction with a 24 GeV proton beam with up to 20×10^{12} ppp. The target system includes instruments for sensing mercury vapor, temperature, flow rate, and sump tank level, and the means to position the jet relative to the magnetic axis of a solenoid and the proton beam. The design considerations for the system include all issues dealing with safely handling approximately 23 liters of Hg, transporting the target system and the mercury to CERN, decommissioning the experiment, and returning the mildly activated equipment and Hg to the U.S.

© 2001 Elsevier Science. All rights reserved

Mercury jet; muon collider target; high-field solenoid; syringe pump; titanium alloy window.

*Tel.: +1-865-574-9602; fax: +1-865-574-5479; e-mail: gravesvb@ornl.gov.

1. Introduction

The mercury jet target system is part of a proof-of-principle experiment to investigate the interaction of a proton beam, high magnetic field, and high-Z target. In principle, it is similar to a high-power production target needed for a neutrino factory or muon collider. The system consists of a free-jet mercury target situated inside a 15-T solenoid, fitted with a laser optic system to observe the interaction of the jet and the proton beam in the magnetic field [1]. The experiment is planned for 2007 in the TT2A tunnel at CERN, and the experiment has been designated as nTOF11. The target system will have double containment and be capable of delivering a minimum of 100 jet cycles into a proton beam line. Figure 1 shows the target system; the protruding end is that which is inserted into the bore of the solenoid.

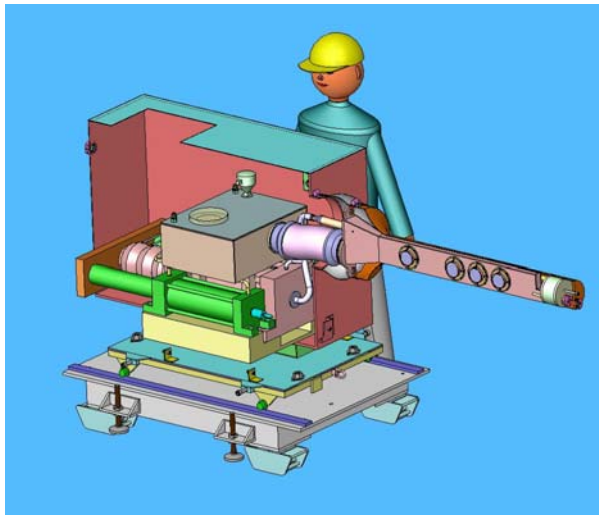

Fig. 1: Cutaway view of the target system.

The target system consists of four subsystems: the primary-containment structure, a secondary-containment structure, a hydraulically actuated syringe pump system, and the support base structure. The design for each subsystem must take into account the

requirements for dealing with mercury, a toxic heavy metal that will become mildly activated once testing commences, and the requirements for dealing with a mildly radioactive structure at the completion of testing.

The system will operate in a 1-atm environment of air for both the primary and secondary containments. Air activation (i.e., ^{13}N , ^{15}O , and ^{41}Ar) will not be an issue for this system since the air environment is not purged after each pulse and the containment boundaries remain intact for the duration of testing. If there is a need to breach either barrier after test operations commence, 1 h of waiting will be sufficient for the decay of these isotopes. This approach is simpler than incorporating equipment to evacuate and backfill with helium.

2. Target System Design

The target system consists of the equipment to operate and contain a continuous mercury jet that can be sustained for a maximum of 12 s. The jet is produced by a syringe pump that is hydraulically driven. The target system is being designed such that the elemental mercury in the target is double contained and mounted on a base structure that supports the target equipment and the solenoid system as an integrated unit. The support structure will be capable of being manually maneuvered into or out of the axis of the proton beam line, and it has provisions for adjusting the elevation and pitch of the integrated system.

The target system is initially assembled and tested “hands on” but must be maintained and operated with minimal personal contact after beam operations commence. Therefore, design of the target system takes into account the eventual disassembly and decontamination of the equipment. Design features are incorporated into the target system to simplify the handling of mildly activated components that are mercury contaminated as well as the handling of activated mercury, so as to minimize exposure to personnel. At the completion of the CERN tests, the

target system and the mercury will be returned to Oak Ridge National Laboratory (ORNL) for future use in developing high-power targets. Figure 2 is a schematic diagram of the target system and the containment boundaries.

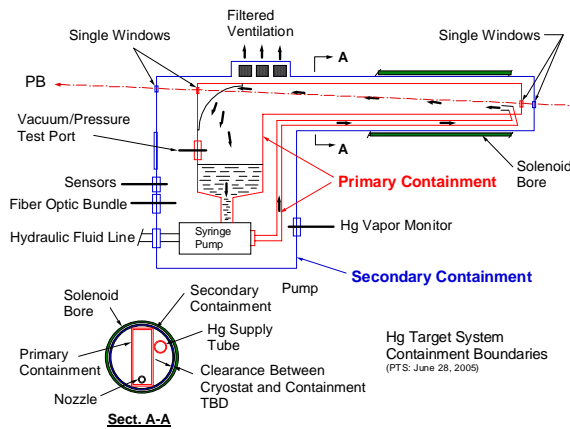

Fig. 2: Schematic diagram of the target system.

2.1. Design Specification

The fundamental requirement for the target system is to deliver a 1-cm-diameter jet of mercury with a velocity of up to 20 m/s, fully interacting with protons along 30 cm of beam line. A flow rate of 95 L/m (25 gpm) is required to meet the velocity specification. In addition, the target system is being designed to meet the criteria of ISO 2919, "Table 2—Classification of Sealed Source Performance—Class 2," since the elemental mercury will become mildly activated. These requirements are as follows:

- temperature: -40°C (20 min), $+80^{\circ}\text{C}$ (1 h);
- external pressure: 25 kPa absolute (60 psi) to atmospheric;
- impact: 50 g from 1 m, or equivalent imparted energy;
- vibration: 3 times 10 min, 25–500 Hz at 49 m/s^2 ($5 g_n$, acceleration maximum amplitude); and

- puncture: 1 g from 1 m, or equivalent imparted energy.

2.2. Geometry

The geometric requirement for the target system is based on the following criteria:

- The proton beam is parallel to and $121\text{ cm} \pm 5\text{ mm}$ ($47.64 \pm 0.20\text{ in.}$) above the horizontal tunnel floor.
- The proton beam, solenoid axis, and mercury jet all reside in a common vertical plane.
- The service end of the solenoid (i.e., the location of electrical and cryogenic connections) is "up-beam."
- The solenoid axis is tilted 67 m (3.84°) with respect to the proton beam, with the up-beam end of the solenoid elevated above the beam.
- The mercury jet flows from the "up-beam" to the "down-beam" direction, the same direction as the proton beam.
- The mercury jet begins below the proton beam at an angle of 33 milliradians (1.89°) to the beam.
- The jet nozzle is to be positioned so that the jet center crosses the beam center at $Z = 0$, the center of the solenoid.

2.3. Instrumentation

The target system will be instrumented with the following sensors, each having readout capability remotely located in a control room $\sim 50\text{ m}$ away:

- a mercury vapor sensor to monitor the atmosphere in the secondary containment,
- a temperature sensor to monitor mercury temperature in the sump tank,
- a position sensor on the syringe pump cylinder to monitor mercury flow in the supply line,
- a level sensor to monitor the quantity of mercury in the sump tank,
- a conductivity sensor to detect mercury that could collect in the base of the secondary containment, and
- leak detection of the interstitial space in the secondary-containment beam windows.

2.4. Optical Diagnostic

A pulsed laser optical diagnostic connected to a high-speed charge-coupled device (CCD) camera will be used to view the behavior of the mercury jet as it interacts with the proton beam. Three viewing ports will be incorporated into the primary containment, each consisting of a quartz window where laser light is directed perpendicular to the jet. A spherical mirror will be mounted on the opposite side of each port, also on the primary containment. Because the jet is opaque, the images obtained are the shadow of the jet. The ports will be located at beam axis locations $Z = -15$ cm, 0 cm (center of the solenoid), +15 cm, and +30 cm. The diagnostic system is being designed at Brookhaven National Laboratory (BNL).

2.5. Beam Windows

Proton beam windows will be mounted to the primary and secondary containments of the target system. The windows will be fabricated from titanium alloy, Ti6Al4V. The up-beam and down-beam windows of the primary containment will be single-thickness material, while the secondary-containment windows will be double thickness to permit interstitial leak detection to be used to monitor for a possible window failure. The windows are being designed at BNL.

3. Test Plan

The target system will undergo a series of functional and operating tests before being shipped to CERN for the in-beam experiment.

Systems testing will be performed at ORNL after the equipment has been fabricated and assembled. The completely assembled system includes the pump equipment, the primary and secondary containments, the control system, the laser optics, the beam windows, and up to 23 L of mercury. (Twenty-three liters is based on a system capable of delivering 12 s of jet.) The tests at ORNL will be used to characterize the performance

of the equipment, verify the leak tightness of the equipment, calibrate and verify the timing of the controls, and confirm operation of the sensors and optical diagnostic system. Initial systems tests will be performed using a water/glycol mixture; once successful operation has been demonstrated, mercury will be loaded into the system for final testing.

The equipment will then be shipped to Massachusetts Institute of Technology (MIT) for integrated system tests with the solenoid. The testing at MIT will repeat all of the tests listed above but under varying magnetic fields up to 15 T. These tests will verify setup and operation of the integrated system prior to shipment to CERN and will also verify the integrity of the target interfaces with the magnet system.

The experiment at CERN will repeat all of the MIT tests but with the addition of a proton beam. Up to 100 pulses (tests) will be done at CERN for the proof-of-principle testing. At the completion of these tests the target system and the mercury will be mildly activated. Therefore, the equipment will remain in the TT2A tunnel for a cool-down period sufficient to permit hands-on dismantling of the components. Figure 3 shows the target/solenoid equipment installed in the beam-line path. (Note the angle of the target/solenoid components relative to the horizontal beam line shown in red.)

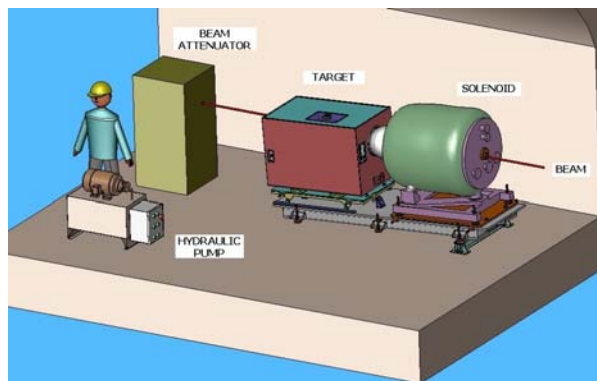

Fig. 3: Target and solenoid installed in the tunnel.

4. Safety Considerations

The primary safety considerations focus on transporting and handling elemental mercury before and after it becomes activated, containing mercury and its vapors during testing, and decommissioning the activated equipment and preparing it for shipment back to ORNL. A preliminary estimate of activation [2] indicates that after 200 pulses with 16×10^{12} protons per pulse and 30 days of operation, a contact dose at $Z = 0$ on the outer surface of the solenoid will be as follows:

- 40 mrad/h after 1 h,
- 21 mrad/h after 1 day,
- 13 mrad/h after 1 week,
- 5 mrad/h after 1 month, and
- 1 mrad/h after 1 year.

It is expected that dose-rate levels at other locations around the equipment will be lower. Therefore, limited access to the equipment during the CERN tests, although not anticipated, is possible after a cool-down period of days.

5. Decommissioning Plan

Once the experiment has concluded, the equipment will be moved out of the beam line after a cool-down period of several days. It is anticipated that hands-on access to the components will be possible after a period of at least 1 month. The target system has been designed so that the bulk of the mercury can be transferred from the system to appropriate shipping containers without opening the primary or secondary containment. This will occur within the TT2A tunnel. All target system components, including the activated mercury, will be returned to ORNL. U.S. and European Union packaging and shipping standards for the activated equipment and the mercury will be followed.

6. Conclusion

A free-jet mercury target system is being designed at ORNL to support a proof-of-principle experiment planned for 2007 at CERN. The mercury jet will have a velocity of up to 20 m/s at a flow of 95 L/m and will be powered by a hydraulically driven syringe pump. The amount of mercury needed for a 12-s jet is 23 L of elemental mercury. The jet will interact with a 24-GeV proton beam in a 15-T magnetic field. A laser optical diagnostic coupled to a high-speed CCD camera will be used to record the interaction of the jet and the beam.

7. Acknowledgements

This work is supported by the U.S. Department of Energy.

References

- [1] J.R.J. Bennett et al "Studies of a Target System for a 4-MW, 24-GeV Proton Beam," A Proposal to the ISOLDE and Neutron Time-of-Flight Experiments Committee, CERN-INTC-2004-016, INTC-P-186, April 26, 2004.
- [2] H. Kirk, "Residual Contact Dose Rates," High Power Hg Target Meeting, ORNL, September 1, 2004.