

IDS120j WITHOUT RESISTIVE MAGNETS

MODIFYING Hg MODULE

Nicholas Souchlas, PBL (11/1/2012)

IDS120j GEOMETRY, NO RESISTIVE COILS: WITH 20 cm GAPS

MODIFYING Hg MODULE TO SIMULATE VAN GRAVE'S DESIGN.

DETAILS OF VARIOUS DIMENSIONS TO BE DETERMINED AND/OR CLARIFIED.
WE MUST MINIMIZE THE LOSS OF SHIELDING MATERIAL ESPECIALLY
AROUND THE TARGET REGION (FIRST ~ 2 m OF CRYO#1)

>SIMULATIONS CODE: mars1512 (USING MCNP CROSS SECTION LIBRARIES)

>NEUTRON ENERGY CUTOFF: 10^{-11} MeV

>SHIELDING: 60% W + 40% He (WITH STST VESSELS)

>PROTON BEAM POWER: 4 MW

>PROTON ENERGY: $E = 8$ GeV

>PROTON BEAM PROFILE: GAUSSIAN, $\sigma_x = \sigma_y = 0.12$ cm

>EVENTS IN SIMULATIONS : $N_p = 500,000$ (OR 4x500,000 FOR SC#1+2)

IDS120j: GENERAL OVERVIEW (LEFT), POOL REGION DETAILS (RIGHT). [20 cm GAPS]

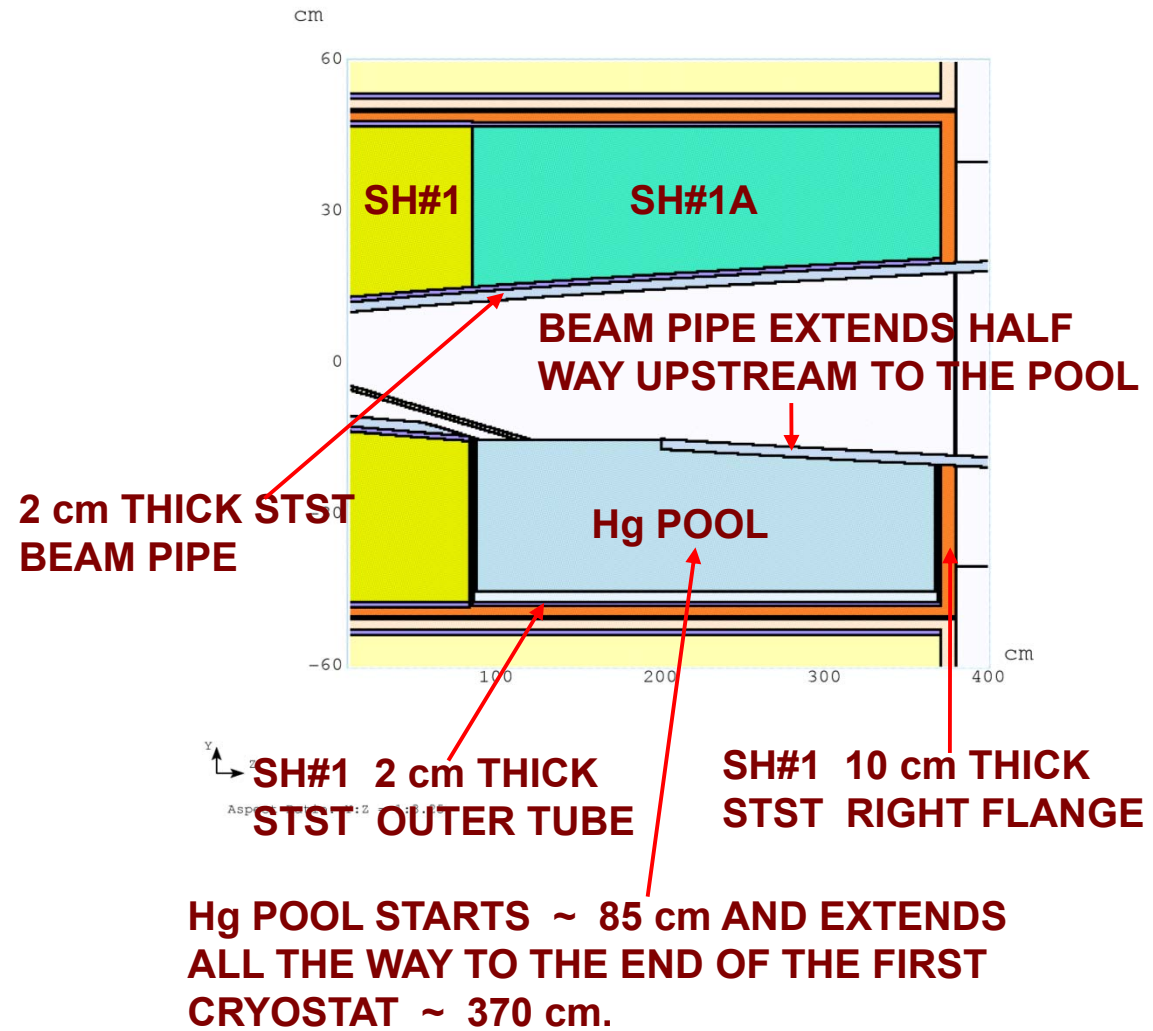
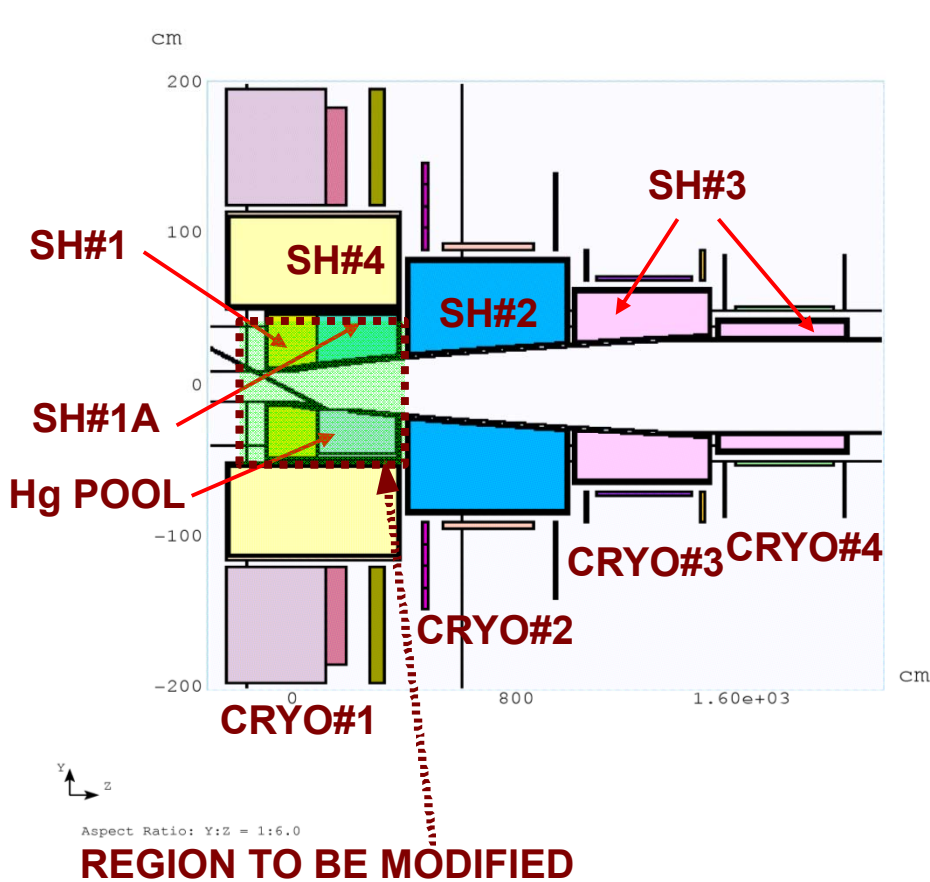

THE NEW Hg POOL MODULE WILL DISPLACE A LARGE VOLUME OF SHIELDING MATERIAL IN SH#1 AND THE FIRST HALF OF SH#1A (TOP VOLUME REGION), WHERE IT IS MOSTLY NEEDED FOR THE PROTECTION OF SC#1 - SC#4.

IDS120j: WITHOUT RESISTIVE MAGNETS. DETAILS OF THE DOUBLE STST Hg POOL VESSEL (LEFT, MIDDLE) AND THE DOUBLE Be WINDOW (RIGHT). [20 cm GAPS]

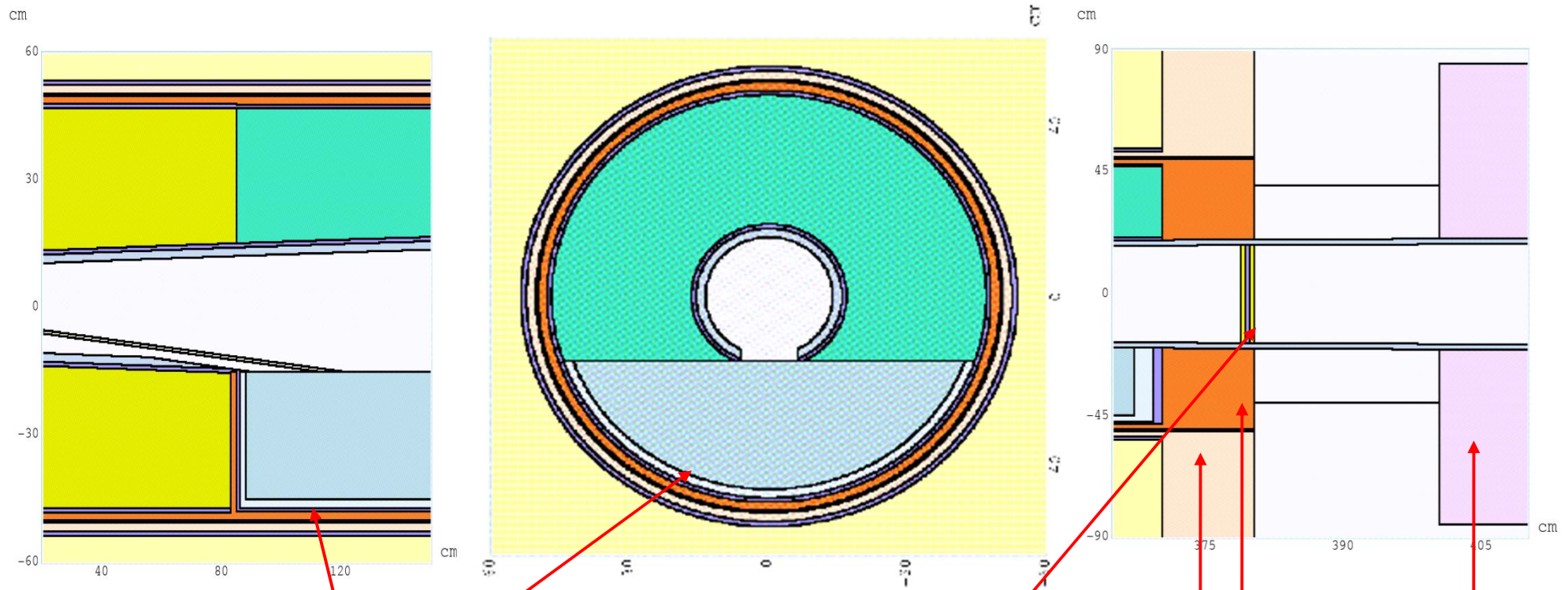

2 cm THICK STST INNER Hg POOL VESSEL WITH 1 cm He GAP FOR COOLING.

TWO 0.5 cm THICK Be WINDOWS AT THE END OF CRYO#1 WITH 0.5 cm He GAP BETWEEN THEM FOR COOLING.

10 cm THICK STST RIGHT / LEFT FLANGE OF SHVS#4, SHVS#1 / SHVS#2 WITH 20 cm GAP BETWEEN THEM.

IDS120j: yz (LEFT) AND yx AT z=0.0 cm (RIGHT) CROSS SECTION WITH DETAILS OF Hg POOL MODULE BORDERS COMPARED WITH THE OLDER DESIGN.

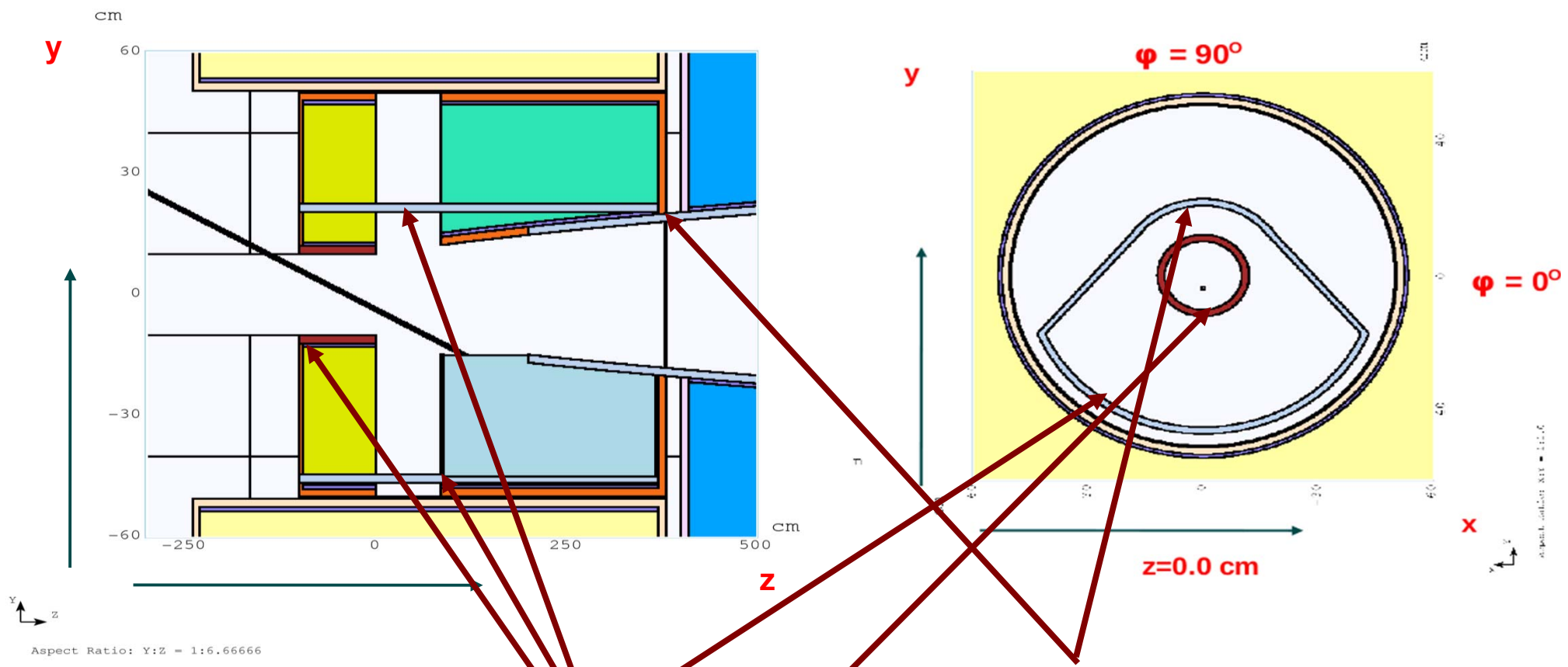

NEW SH#1 INNER VESSEL TO HATCH THE Hg POOL STST DOUBLE WALL MODULE.

SEMICIRCULAR UPPER HALF OF Hg POOL MODULE INNER VESSEL WILL MATCH THE APPERTURE OF THE BEAM PIPE AT THE END OF CRYO#1 (R ~ 17 cm). THAT WILL MINIMIZE THE LOSS OF SHIELDING UPSTREAM.

ORIGINAL BP#1 I = 100 cm LONG STRAIGHT SECTION OF BEAM PIPE IN TARGET REGION WITH R = 10 cm WILL BE REPLACED WITH BELL LIKE BEAM PIPE.

IDS120j: yz CROSS SECTIONS WITH DETAILS OF Hg POOL MODULE FROM VAN GRAVE'S PRESENTATION (8 / 9 / 2012).

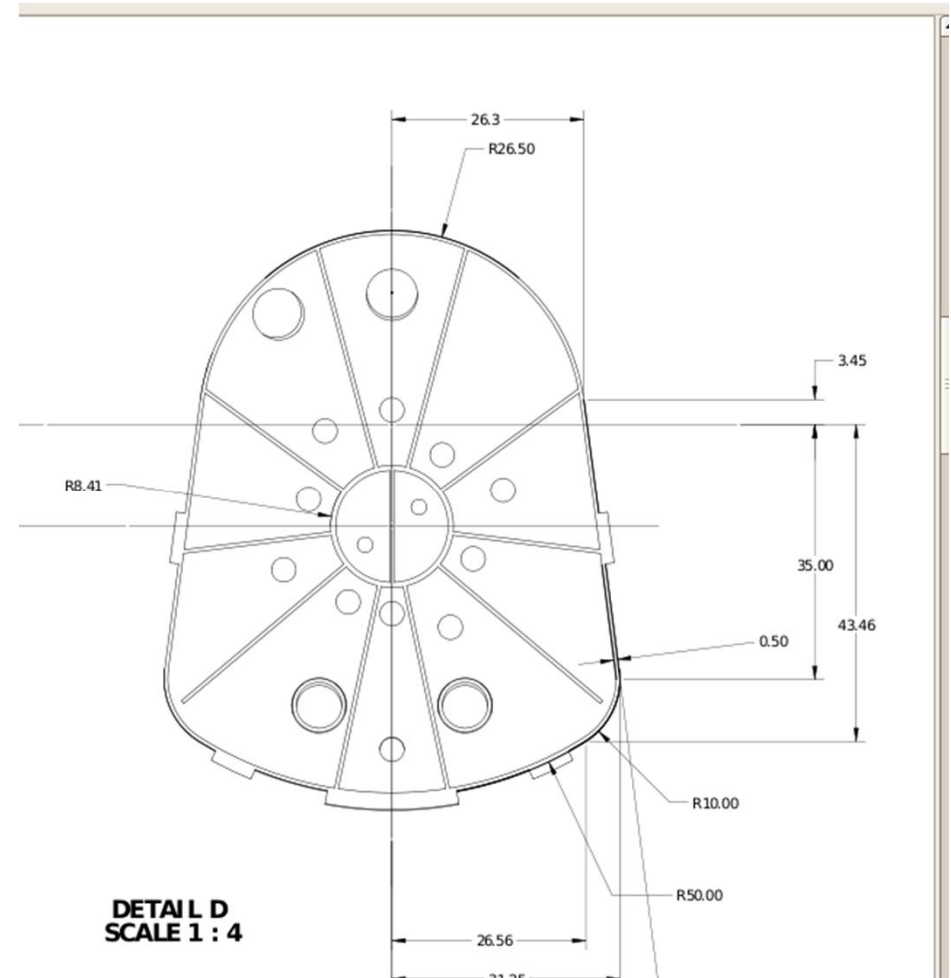
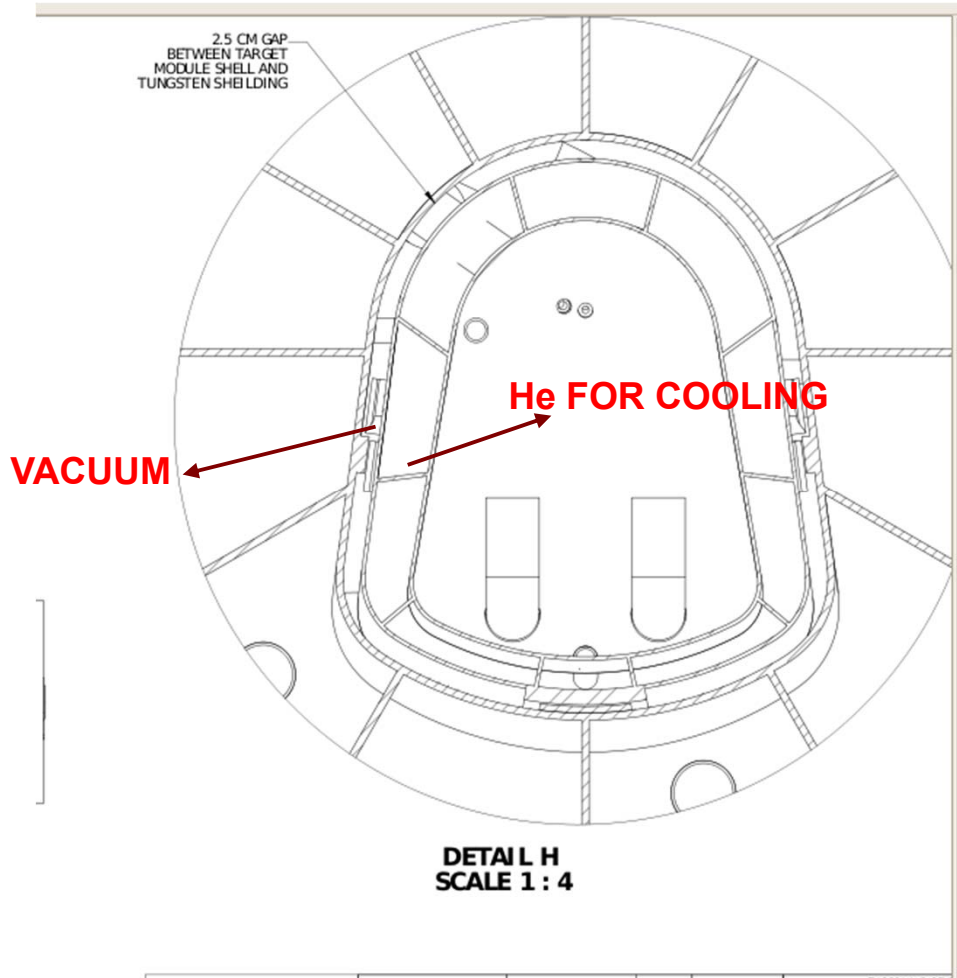

THE DESIGN REQUIRES A 2.5 cm ! GAP BETWEEN SH#1 INNER VESSEL AND Hg POOL MODULE OUTER VESSEL. AN EVEN LARGER SPACE APPEARS TO BE BETWEEN INNER AND OUTER VESSEL OF THE Hg POOL MODULE FOR THE FLOW OF He GAS FOR COOLING THE POOL. THE RADIUS OF THE UPPER HALF SEMICIRCULAR SECTION OF INNER Hg POOL VESSEL WILL BE 26.5 cm, MUCH LARGER THAN THE BEAM PIPE APERTURE AT THE END OF CRYO#1 (~ 17.7 cm).

IDS120j: yx CROSS SECTION WITH DETAILS OF Hg POOL MODULE FROM VAN PLOTS (LEFT) AND ADAPTED DESIGN FOR MARS SIMULATIONS (AT z = 100 cm).

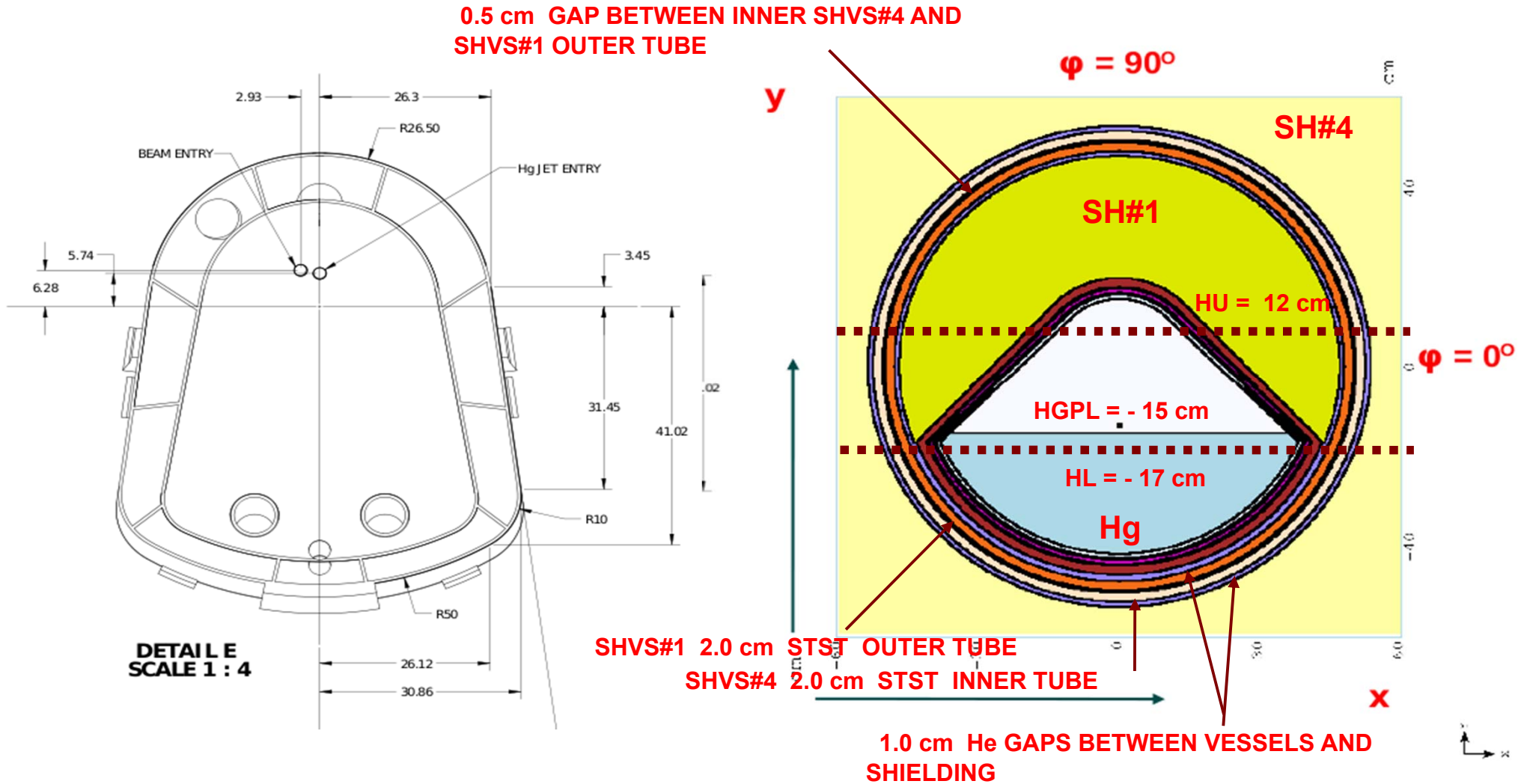

EVERYTHING HAS BEEN PARAMETRIZED FOR FUTURE CONVINIENCE. THE HEIGHTS OF THE END POINTS OF THE STRAIGHT SECTIONS ARE HL = - 17 cm AND HU = 12 cm. THE FREE Hg POOL SURFACE IS AT y = - 15 cm. THE RADIUS OF THE LOWER HALF OF THE INNER VESSEL OF THE Hg MODULE IS NOW SMALLER THAN BEFORE : FROM ~ 45 cm ----> ~ 42 cm. THE REST OF THE SPACE BETWEEN SHVS#1 INNER AND OUTER TUBE IS FILLED WITH SHIELDING.

IDS120j: yx CROSS SECTION AT z = 100.0 cm WITH DETAILS OF THE HG MODULE UPPER SIDE.

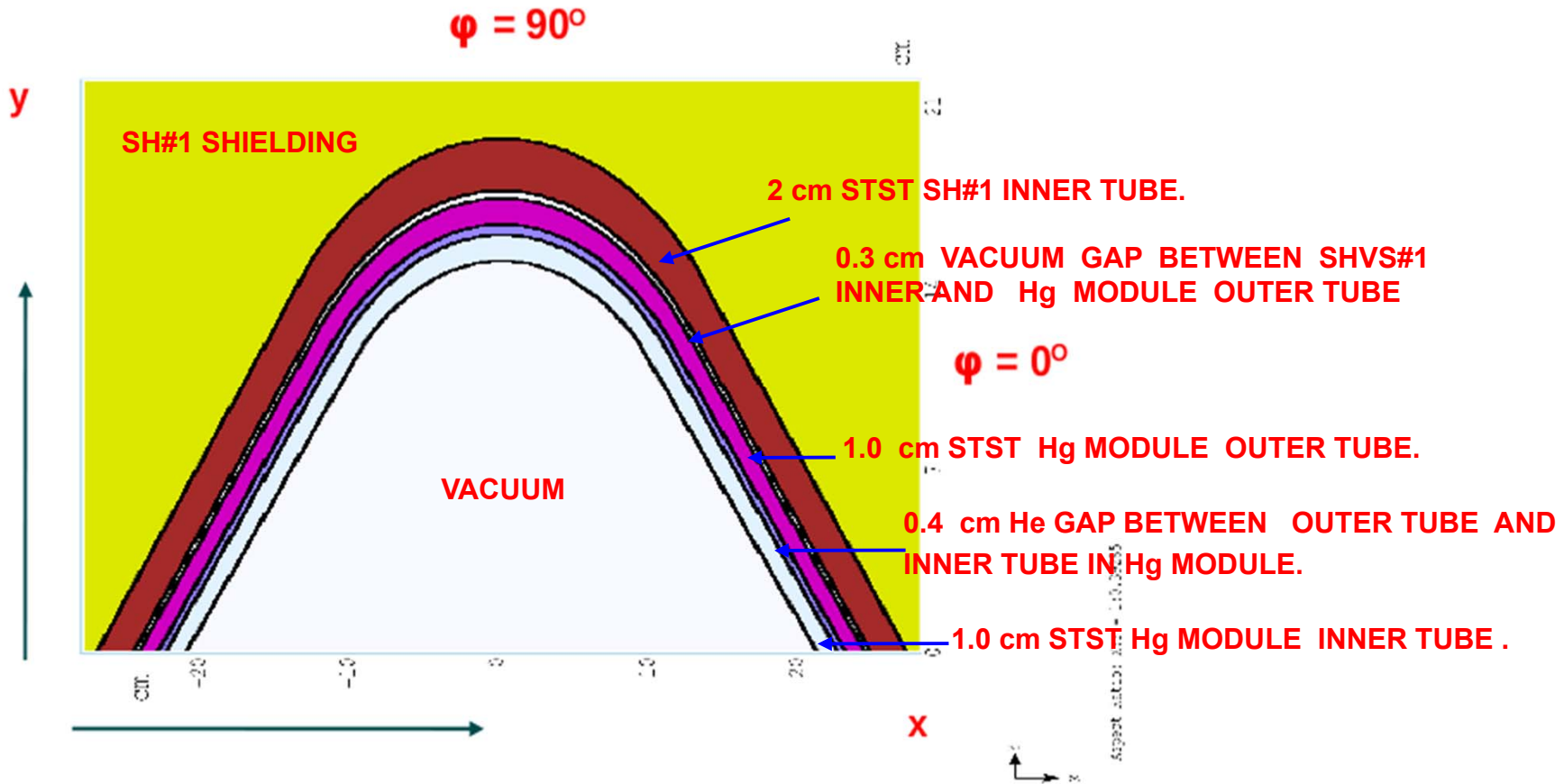

ALL TUBES THICKNESSES AND GAPS SIZE ARE PARAMETRIZED. SHVS#1 INNER TUBE THICKNESS IS SET TO 2.0 cm TO SUPPORT THE SHIELDING WEIGHT, THE LOWER Hg MODULE INNER TUBE CAN ALSO BE THICKER TO SUPPORT THE WEIGHT OF Hg IN THE POOL. [ARE THESE NUMBERS I SET UP REASONABLE ?]

IDS120j: yz CROSS SECTION WITH DETAILS OF THE NEW Hg MODULE AND THE LOWER HALF OF THE UPSTREAM REGION. [20 cm GAPS]

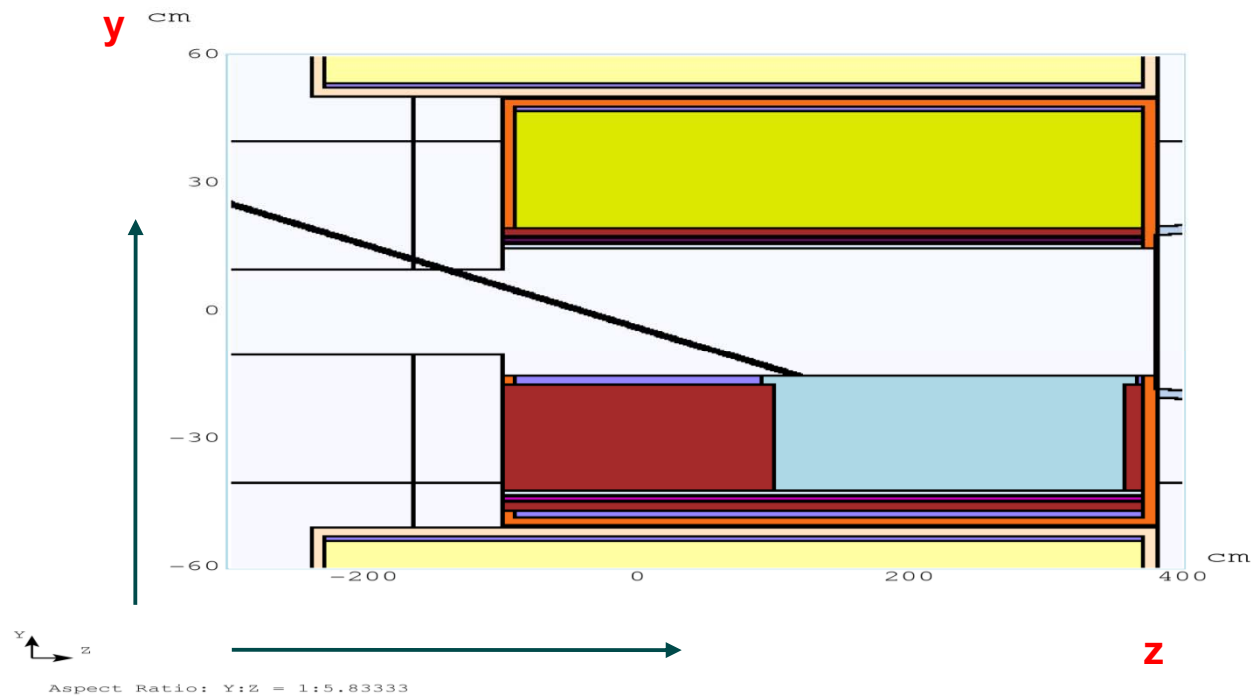

WHAT CONFIGURATION OF THE SHIELDING MATERIAL BEFORE THE POOL IS ACCEPTABLE FOR ENGINEERING PURPOSES ?

A) IS IT POSSIBLE TO KEEP THE SAME AS BEFORE ?

[FROM $-100 < z < 0$ cm, $10 < r < 50$ cm FILLED WITH SHIELDING AND THEN A SMALL VOLUME WITH VARYING r TO CONNECT WITH THE NEW Hg MODULE] * BEST CHOICE *****

B) THE UPPER HALF WILL FOLLOW THE Hg MODULE SHAPE AND THE LOWER PART WILL BE FILLED WITH SHIELDING UP TO $y = -10$ cm, CLOSE TO THE POOL WILL GRADUALLY DECREASE TO MEET THE POOL LEVEL AND ALLOW THE JET ENTER THE POOL. * SIGNIFICANT LOSS OF SHIELDING IN TARGET REGION *****