

On the History of the Radiation Reaction¹

Kirk T. McDonald

Joseph Henry Laboratories, Princeton University, Princeton, NJ 08544

(May 6, 2017; updated March 18, 2020)

1 Introduction

Apparently, Kepler considered the pointing of comets' tails away from the Sun as evidence for radiation pressure of light [2].² Following Newton's third law (see p. 83 of [3]), one might suppose there to be a reaction of the comet back on the incident light. However, this theme lay largely dormant until Poincaré (1891) [38, 42] and Planck (1896) [47] discussed the effect of “radiation damping” on an oscillating electric charge that emits electromagnetic radiation.

Already in 1892, Lorentz [39] had considered the self force on an extended, accelerated charge e , finding that for low velocity \mathbf{v} this force has the approximate form (in Gaussian units, where c is the speed of light in vacuum), independent of the radius of the charge,

$$\mathbf{F}_{\text{self}} = \frac{3e^2}{3c^3} \frac{d^2\mathbf{v}}{dt^2} = \frac{2e^2\ddot{\mathbf{v}}}{3c^3}. \quad (v \ll c). \quad (1)$$

Lorentz made no connection at the time between this force and radiation, which connection rather was first made by Planck [47], who considered that there should be a damping force on an accelerated charge in reaction to its radiation, and by a clever transformation arrived at a “radiation-damping” force identical to eq. (1). Today, Lorentz is often credited with identifying eq. (1) as the “radiation-reaction force”, and the contribution of Planck is seldom acknowledged.

This note attempts to review the history of thoughts on the “radiation reaction”, which seems to be in conflict with the brief discussions in many papers and “textbooks”.³

2 What is “Radiation”?

The “radiation reaction” would seem to be a reaction to “radiation”, but the concept of “radiation” is remarkably poorly defined in the literature.

The author's view [181] is that electromagnetic radiation should be identified with the Poynting vector [28], $\mathbf{S} = (c/4\pi)\mathbf{E} \times \mathbf{B}$, where \mathbf{E} and \mathbf{B} are the electromagnetic fields. In the literature on the “radiation reaction”, the notion of “radiation” is generally restricted to the Poynting vector at large distances from the source charge/current, as reinforced by

¹An earlier set of comments by the author related to the radiation reaction is given in [1].

²Several inconclusive attempts to confirm Kepler's conjecture are reviewed in [117].

³In 1969, Ginzburg [129] noted that the question of the radiation reaction is something of a “perpetual problem”, and like many others claimed that his discussion would settle the issue. The author is not so sanguine, and supposes that, despite this note, the radiation reaction will continue to be a “perpetual problem” for most readers.

the so-called “Sommerfeld radiation condition” [95, 166].⁴ However, the flow of energy and momentum in electromagnetic fields far from their source does not necessarily reflect the flow at the source.⁵

3 Stewart and a Reaction to Radiation

In 1871, Balfour Stewart [17] discussed the interaction of a body in motion inside a cavity that contained blackbody radiation, stating: *The body in motion in the enclosure is not therefore giving the precise rays which it would have given it had it been at the same temperature and at rest.* And further: *It is not therefore, allowable to suppose that in such an enclosure the moving body retains all its energy of motion, and consequently such a body will have its energy of motion gradually stopped.*

These comments may be the first relatively clear statement of an effect of a “radiation reaction”, although Stewart considered only thermal radiation/light by electrically neutral objects, and did not follow Maxwell in identifying light with electromagnetic radiation.⁶

In 1873, Stewart [20] briefly discussed “æthereal friction,” which is a different way of characterizing Maxwell’s radiation pressure (sec. 4 below).

4 Maxwell and Radiation Pressure

Although Maxwell famously identified light with electromagnetic waves (p. 22 of [11]), he did not live long enough to consider generation of such waves by electrical devices. In Arts. 792-793 of his *Treatise* (1873) [19] he discussed the “energy and stress of radiation”, and noted that when a plane electromagnetic wave is absorbed by a plate, the effect on the plate is a kind of (radiation) pressure. He did not discuss the back reaction of the object on the electromagnetic wave, which occurs for a reflecting plate that can be considered to re-emit the absorbed wave, thereby doubling the radiation pressure.

⁴Although “radiation” in the broad sense of transfer of energy via an electromagnetic field [181] exists in all electrical devices that contain currents (including steady currents) in resistive materials, the concept of radiation played essentially no role in the early history of electricity and magnetism. While electromagnetic radiation in the form of waves exists in (almost) all electrical devices that have time-dependent charge and/or current distributions, and was present, for example, in Faraday’s earliest studies [4] of electromagnetic induction, the wave character of the radiation plays little role unless the time dependence is rapid enough that the wavelength of the radiation is similar to (or smaller than) the size of the devices.

⁵An early, partial awareness of this issue underlies the debate, beginning with Born (1909), sec. 18 below, as to whether or not a uniformly accelerated charge “radiates”, since the radiation-reaction force (1) vanishes in this case. For comments by the author on this theme, see [187]. Another example is the collapse of an electric dipole, initially at rest, in which “radiation” flows outward at large distances, but inward close to the dipole [191]. And in the realm of applied physics, there is the “radiation paradox” of Schelkunoff (sec. 6 of [113]) that since the electric field can only be normal to the surface of a good/perfect conductor, the Poynting vector can only be parallel to the surface, and no electromagnetic-field energy flows out of the surface of the conductors of an antenna (and flows into the surfaces of resistive conductors).

⁶Stewart did subscribe to a wave (undulatory) theory of heat, as opposed to a particle (emissive) theory, as he discussed in secs. 179 and 387 of [12].

5 Crookes and Cathode Rays

The radiation reaction is an effect related to elementary charged particles, but such entities were not part of Maxwell’s vision of electrodynamics, in which electric charge was a continuous distribution ρ associated with a “strain” in the æther, $\rho = \nabla \cdot \mathbf{D}$.⁷ The notion that charge is a property of particles gained strength from dramatic experiments with evacuated tubes equipped with electrodes. This technology was introduced in the 1850’s by Plücker and his assistant Geissler [9, 10],⁸ and was popularized by Crookes in the 1870’s [21, 24].

For example, in the apparatus sketched below (from [24]), a beam emanated from the cathode (e), and these “cathode rays” were deflected by a magnetic field perpendicular to the page, rather than striking the anode (f) as they did for zero field.

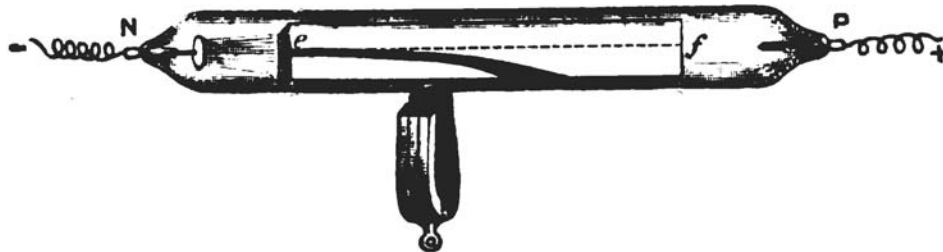

Such experiments suggested that negatively charged particles were being emitted into the vacuum (although it was not logically excluded that the beam was a continuous fluid).^{9,10} They also provided evidence in favor of the $\mathbf{J} \times \mathbf{B}$ force (*i.e.*, the $q\mathbf{v} \times \mathbf{B}$ Lorentz force), discussed by Maxwell in Arts. 602-603 of his *Treatise* [19].

6 J.J. Thomson and Electromagnetic Mass

In 1881, J.J. Thomson (age 25) [25] was inspired by Crookes’ results to consider the electromagnetic fields of a slowly moving charged particle (which surprisingly had not been previously discussed in the literature). In particular, the magnetic field is proportional to the velocity of the charge, so the magnetic field energy, $U_B = \int B^2 d\text{Vol}/8\pi$, goes as the square of the velocity, as does the kinetic energy of the particle. Thomson took the bold step of supposing that this magnetic energy is effectively part of the particle’s mass, which is perhaps the first example of what has come to be called mass “renormalization”,¹¹ as well

⁷In contrast, elementary charged particles were central to Weber’s electrodynamics (1846) [6].

⁸Plücker noted that the pattern of the glow in discharge tubes was affected by a magnetic field, and characterized this phenomenon as “magnetic light”.

⁹In 1894 these “atoms of electricity” were named “electrons” by Stoney [43].

¹⁰The above experiment of Crookes was not qualitatively distinct from that of Thomson (1897) [48], which is credited with the “discovery” of the electron.

¹¹Already in 1843, Stokes (age 24) had argued, p. 106 of [5], that *when a cylinder oscillates in an infinitely extended fluid, the effect of the inertia of the fluid is to increase the mass of the cylinder by that of the fluid displaced*. Stokes did not propose that the mass of the displaced fluid be considered as part of the mass of the cylinder.

Following present usage, we could say that the cylinder was “dressed” by the fluid close it, which increased its effective mass. The cylinder + interacting fluid could then be regarded as a “quasiparticle”.

The theme of an effective mass of “sunlight”, was pursued by W. Thomson in 1855 [7], without associating light with electromagnetism.

as of the concept of “relativistic mass”, $m = m_0/\sqrt{1 - v^2/c^2}$, where m_0 is the rest mass of particle with speed v .¹²

In eq. (3) of [25], Thomson identified the quantity ke^2/ac^2 , where a is the radius of a charged sphere, as having dimensions of mass, but he did not go so far as to suppose that the entire mass of a charge is thereby explained (which would imply that $a/k = e^2/mc^2 =$ the so-called classical charge radius).

7 FitzGerald and Radiation by an Oscillating Current Loop

The first calculation of the radiation electromagnetic energy by an electrical current was given by FitzGerald in 1883 [27, 180], one year before Poynting [28] introduced his vectorial measure of the flow of electromagnetic field energy. FitzGerald’s result for the time-averaged power $\langle P \rangle$ radiated by a current with time dependence $I_0 \cos \omega t$ can be written (in Gaussian units) as,

$$\langle P \rangle = \frac{I_0^2 R_{\text{rad}}}{2}, \quad \text{where} \quad R_{\text{rad}} = \frac{2\pi^2}{3c} \left(\frac{L}{\lambda} \right)^4 = 197 \left(\frac{L}{\lambda} \right)^4 \Omega, \quad (2)$$

where R_{rad} is the so-called radiation resistance, where $L \ll \lambda$ is the circumference of the loop, and $\lambda = 2\pi c/\omega$.¹³

8 Hertz and Electric-Dipole Radiation

In 1887, Hertz began experiments [29, 30, 31] (sketched below) with what is now called an electric-dipole antenna, driven by an induction (Ruhmkorff) coil/spark gap, together with a loop antenna at whose gap sparks could be induced by waves from the first antenna.

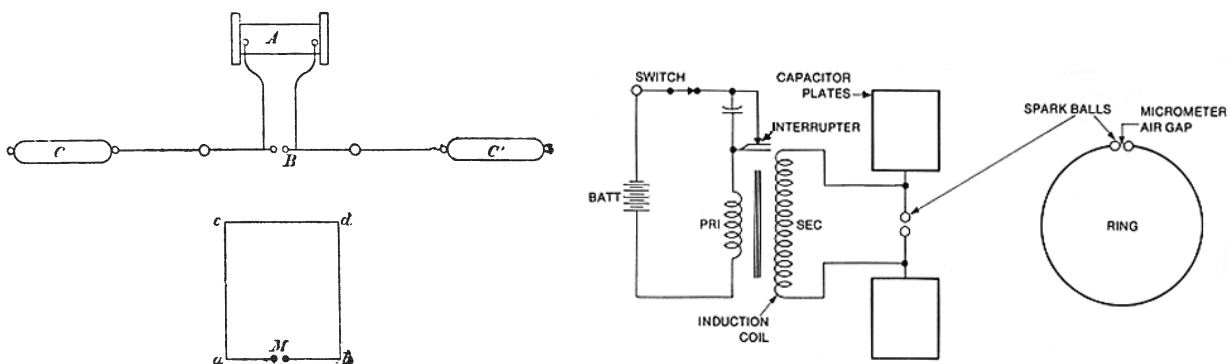

¹²There exists a campaign [163] to deny the existence of “relativistic mass”, or at least that Einstein had anything to do with this concept, and hence that it should not be discussed.

¹³The “natural” unit of electric resistance is $1/c = 30 \Omega$. The concept of “natural” units was popularized by Planck (1899) in [51], where the Planck length $= \sqrt{\hbar G/c^3} \approx 10^{-33}$ cm was first introduced.

In 1889, he gave an analysis [34, 35], using the Poynting vector, that the instantaneous radiated power can be written as,

$$P = \frac{2p_0^2 \omega^4 \cos^2 \omega t}{3c^3}, \quad (3)$$

where $L \ll \lambda$ is the total length of the antenna, $p = p_0 \cos \omega t$ is its electric-dipole moment, which is related to the current $I_0 \sin \omega t$ in its spark gap by $p_0 = I_0 L / 2\omega$.

Hertz did not describe the time-averaged radiated power as,

$$\langle P \rangle = \frac{I_0^2 R_{\text{rad}}}{2}, \quad \text{where} \quad R_{\text{rad}} = \frac{2\pi^2}{3c} \left(\frac{L}{\lambda} \right)^2, \quad (4)$$

and R_{rad} is the radiation resistance of the antenna.¹⁴

9 Lodge and Radiation Resistance

In 1889, Lodge translated Hertz' paper [34] into English [35], and repeated many of Hertz' experiments [36]. On p. 153 of [36], Lodge remarked that the power radiated in the apparatus of Hertz “may be compared with the form V^2/R ”, where V is the “difference in potential between its ends” and R is a resistance. This appears to be the first conception of the radiation resistance associated with an electrical circuit that emits radiation.¹⁵

10 Poincaré and *Amortissement*

Hertz' achievements had considerable immediate impact, including commentaries by Poincaré, (1891) [38] and secs. 47-48, pp. 92 ff, of [42], that mentioned the *amortissement* (damping) of a Hertzian electrical oscillator due to its emission of energy in the form of radiation.¹⁶

11 Radiation Resistance *vs.* Radiation Reaction

The radiation resistance, which is to be included in circuit analyses of devices that emit radiation, is the most practical application of the “radiation reaction”, as discussed in sec. 2.2 of [176].

The radiation resistance (2) for a loop of radius $r = L/2\pi$ can be deduced from the radiation-reaction force $\mathbf{F}_{\text{react}} = -e^2 r^2 \ddot{\mathbf{v}} / 6c^5$ on electrons of charge e moving in that loop.

¹⁴In early experiments on antennas with spark gaps it was hard to distinguish the radiation resistance from the resistance of the spark (plasma). See, for example, [60].

¹⁵In 1898, Abraham (age 23) [49] considered the *Dämpfung durch Ausstrahlung* of an electric-dipole antenna (consisting of two halves of a prolate spheroid). In 1902, eq. (9) of [59], Abraham gave the power radiated by a particular antenna in a form equivalent to $I_0^2 R/2$ with $R = 36.6 \Omega$, but did not describe this result as involving a resistance. This value was called the *Strahlungswiderstand* (radiation resistance) on p. 459 of [85] (1908).

¹⁶The damping of an electrical oscillator due to Joule heating had been noted in [37].

See secs. 2.3-4 of [176]. This example involves magnetic-dipole radiation (rather than electric-dipole radiation), in which case the leading term, proportional to $\dot{\mathbf{v}}$, vanishes in Lorentz' series expansion for the self force, and the next-to-leading term, proportional to $\ddot{\mathbf{v}}$, dominates. However, the physics literature on the “radiation reaction” is almost exclusively concerned with single electrical charges, which latter cannot be well described in classical electrodynamics. In contrast to the widespread application of the concept of the radiation resistance in antenna engineering, there is essentially no experimental evidence for effects of the classical radiation reaction on single electric charges, which topic remains almost purely a “theoretical” concern, with the character of a “perpetual problem” [129], about which contentious literature (perhaps including this note) continues to be generated.

12 Lorentz' Self Force on an Accelerated Charge

In 1892, Lorentz enunciated his “classical electron theory” [39], that electric charge resides on “particles” (rather than in the æther/fields surrounding such particles, as according to Maxwell [18]).¹⁷ In sec. 120 of [39], Lorentz approximated the retarded potentials of Lorentz [14] and Riemann [13] to order $1/c^3$ to deduce the self force on an accelerated, extended charge e with low velocity ($v \ll c$), finding in his eq. (111) the famous result (in Gaussian units),

$$\mathbf{F}_{\text{self}} = \frac{3e^2}{3c^3} \frac{d^2\mathbf{v}}{dt^2} = \frac{2e^2\ddot{\mathbf{v}}}{3c^3} \quad (v \ll c). \quad (5)$$

That is, Lorentz considered the equation of motion for the charge, of mass m , when subject to an external force \mathbf{F}_{ext} , to be,

$$m\dot{\mathbf{v}} = \mathbf{F}_{\text{ext}} + \mathbf{F}_{\text{self}}. \quad (6)$$

There was no mention of radiation in Lorentz' derivation.

Lorentz continued his development of “electron theory” in [44], and gave a version of his argument for eq. (5) in sec. 20 of [68], and in Note 18 (in English) of [81]. In sec. 21 of [68], and between eqs. (35) and (36) of Note 18 [81], it was clarified that part of the self force could be written as $-ke^2\dot{\mathbf{v}}/r_0c^2$, where r_0 is the radius of the charge and k is a constant of order unity. This was interpreted as the negative of the acceleration $\dot{\mathbf{v}}$ times the “electromagnetic mass” ke^2/r_0c^2 (first noted by J.J. Thomson [25]), and was therefore absorbed (“renormalized”) into the left side of eq. (6), where the effective mass became $m + ke^2/r_0c^2$.^{18,19}

¹⁷For a review of Lorentz' thinking about charges and field prior to [39], see [128].

¹⁸The suggestion that the mass of an electron is entirely due to its electromagnetic field energy may be due to Wien (1900) [58]. In 1902, Kaufmann [65] argued that he had demonstrated this to be so experimentally. Poincaré pointed out in 1905 [79, 80] that the mass of a charge cannot all be electromagnetic, in that for the charge to be stable against the Coulomb repulsion of its parts, there must exist internal stresses that are also associated with mass/energy. These stresses provide a resolution of the so-called 4/3 problem, as reviewed in sec. 91 of [126]. Lorentz later argued [97] that the Poincaré stresses would not render a charge stable against deformations.

¹⁹Lorentz' low-velocity derivation of the self force (5) was embellished by Abraham in 1902 [63], with the

Lorentz may have first noted a relation between his self force (5) and radiation in note 10, pp. 60-62 of [76] (1905). Then, on p. 49 of [81] (1906) he inverted Planck’s argument [47] to show that the time integral $\int \mathbf{F}_{\text{self}} \cdot \mathbf{v} dt$ can be integrated by parts to give a term $-\int (2e^2 \dot{\mathbf{v}}^2 / 3c^2) dt$, without mentioning that this result corresponds to the negative of the radiated power. A connection of this term to radiation was, however, made on p. 259, Note 22 of [81].

In sec. 37 of [81], Lorentz added the comment that his result (5) holds only if the motion of the charge does not change “sensibly” during the time light takes to cross the (extended) charge. *He did not mention that this restriction would exclude so-called “runaway” solutions that have since been considered for the equation of motion of a classical charge. Nor did he mention that this restriction implies that the strengths of the external electric and magnetic fields cannot be arbitrarily large.*²⁰

12.1 Should Lorentz’ Self Force Be “Renormalized” Away?

In view of eq. (5), Lorentz’ equation of motion (6) of an electron with “mechanical” momentum $\mathbf{p}_{\text{mech}} = m\mathbf{v}$ could be written as,

$$m\dot{\mathbf{v}} = \frac{d\mathbf{p}_{\text{mech}}}{dt} = \mathbf{F}_{\text{ext}} + \mathbf{F}_{\text{self}} = \mathbf{F}_{\text{ext}} + \frac{d}{dt} \frac{2e^2 \dot{\mathbf{v}}}{3c^2}, \quad \frac{d}{dt} \left(\mathbf{p}_{\text{mech}} - \frac{2e^2 \dot{\mathbf{v}}}{3c^2} \right) = \mathbf{F}_{\text{ext}}. \quad (7)$$

This suggests that the effective momentum of an electron might be regarded as $\mathbf{p}_{\text{eff}} = \mathbf{p}_{\text{mech}} - 2e^2 \dot{\mathbf{v}} / 3c^2$, in which case the “renormalized” equation of motion might be simply $d\mathbf{p}_{\text{eff}} / dt = \mathbf{F}_{\text{ext}}$, and the peculiar form of the Lorentz’ self force (5) would have no impact on the observable behavior of an electron.

While this procedure has some appeal in giving a “trivial” resolution of the issue of the self force on an electron, it seems inappropriate once one is aware that the self force (5) is related to the reaction on an accelerated charge due to its radiation of electromagnetic energy, as noted by Planck (sec. 13 below). Hence, people have hesitated to “renormalize away” the self force (5), leaving the topic of “classical electron theory” to wrestle with its consequences, which to this day seems (to this author) to be somewhat imperfectly resolved.²¹

An “engineering” argument for continued use of Lorentz’ self force (5) is that it leads to the radiation resistance of antennas, such as eqs. (2) and (4), which is the most “practical”

explicit assumption that the mass of a charge is entirely electromagnetic. Versions of Lorentz’ argument are given in sec. 21-7 of [125], and in sec. 16.3 of [169]. The spirit of Lorentz’ argument is well illustrated in the pedagogic paper [147] (although this paper is too naïve in its claim that the energy of the radiation associated with an accelerated charge must come from its kinetic energy, whereas it can also come from the electromagnetic field energy of that charge, as noted by Schott [96] and discussed in sec. 19 below.

²⁰Another indication of the approximate character of Lorentz’ self force (5) comes from the extension of Planck’s argument (sec. 13) for a radiation-reaction force to higher-order multipole radiation. A single charge not at the origin has nonzero electric and magnetic moments of all orders. If the charge is accelerated, it emits electric- and magnetic-multipole radiation of all orders, of which electric-dipole radiation is typically the strongest. As indicated in [164], and in sec. 2.3 of [176], the radiation-reaction force associated with higher-order multipole radiation depends on higher-order derivatives of the charge’s velocity. In extreme cases, the higher-order derivatives could be larger than $\dot{\mathbf{v}}$, such that a higher-order radiation-reaction force is the largest, and corrections to eq. (5) would be important.

²¹This theme will be considered further in secs. 19, 26 and 30 below.

application of this concept [176].²²

13 Planck and the Radiation Damping Force

In the mid 1890's, Planck became interested in the relation between electromagnetism and thermodynamic aspects of emission and absorption of radiation, as pioneered by Kirchhoff [8].²³ Planck was inspired by Hertz' analysis [31, 34] of his experiments (sec. 8 above) that generated and detected electromagnetic waves at a single frequency, in which the source of these waves was a “resonator” that Hertz interpreted as an oscillating electric dipole. Planck noted (1895) [45] that such a “resonator” could be modeled as a single electric charge e tied to a force center by a “spring”, and that in the steady state (thermal equilibrium) the work done by the driving (external) force F_{ext} , presumably an electromagnetic field, must equal the energy radiated.

In a subsequent paper (1896) [47], Planck gave a more analytic discussion.²⁴ He argued that, for the model where the oscillator is an electric charge e of mass m tied to a spring of constant k in, say, an external electromagnetic wave with electric field \mathbf{E} of the resonant angular frequency $\omega = \sqrt{k/m}$, if the equation of motion were simply,

$$m\ddot{x} + kx = F_{\text{ext}} = eE \cos(\omega t), \quad (8)$$

then the amplitude of the oscillation would grow indefinitely with time. To avoid this physical impossibility, the equation of motion must include a damping term, that is plausibly related to the radiation of energy by the “resonator”, which causes a loss of energy similar to the case of ordinary friction. That is, the equation of motion must actually have the form,

$$m\ddot{x} + kx = F_{\text{ext}} + F_{\text{damping}}, \quad (9)$$

and that in the steady state the time-average work done by the external force equals the radiated energy, such that the time-average work done by the damping force is the negative of this.

The resulting motion of the charge, if steady, has the form $x = x_0 \cos(\omega t + \phi)$, for which the corresponding electric-dipole moment about the origin is $p = ex$. According to Hertz (1889) [34], the “resonator” continuously radiates energy at the rate,²⁵

$$P = \frac{dU_{\text{rad}}}{dt} = \frac{2\ddot{p}^2}{3c^3} = \frac{2e^2\ddot{x}^2}{3c^3}. \quad (10)$$

²²If an antenna emits net momentum at rate $d\mathbf{P}_{\text{rad}}/dt$, then there is a back reaction force on the antenna equal and opposite to this [149], which contrasts with the effect of the self force (5) in generating the radiation resistance experienced by the conduction electrons.

²³For a review of Planck's thinking in this era, see [188].

²⁴Planck mentioned being inspired by Poincaré's discussion, [38] and secs. 47-48, pp. 92 ff, of [42], of the *amortissement* (translated by Planck as *Dämpfung durch Strahlung* = radiation damping) of a Hertzian oscillator.

²⁵While Hertz' result (9) agrees with the Larmor formula [46], the latter was deduced only in 1897, after Planck's analysis [47].

Integrating over the period $T = 2\pi/\omega$ of the steady oscillation, the work done W by the damping force is,

$$\begin{aligned} W &= \int_0^T F_{\text{damping}} \dot{x} dt = - \int_0^T \frac{dU_{\text{rad}}}{dt} dt = -\frac{2e^2}{3c^3} \int_0^T \ddot{x}^2 dt = -\frac{2e^2}{3c^3} \dot{x} \ddot{x} \Big|_0^T + \frac{2e^2}{3c^3} \int_0^T \dot{x} \ddot{x} dt \\ &= \frac{2e^2}{3c^3} \int_0^T \dot{x} \ddot{x} dt. \end{aligned} \quad (11)$$

Hence, it is consistent to identify the damping force as,²⁶

$$F_{\text{damping}} = \frac{2e^2}{3c^3} \ddot{x} = \frac{2e^2}{3c^3} \ddot{v}, \quad (12)$$

which is the same as Lorentz' self force (5) that was deduced by a very different argument, although Planck did not mention this in [47].

Planck's derivation can be regarded as transforming a "radiation reaction" via an integration by parts into "radiation damping" (*Dämpfung durch Strahlung*).

Planck did remark that the equation of motion (9) in the case of zero external force and zero spring constant becomes $\ddot{x} = \tau \ddot{x}$, where $\tau = 2e^3/3mc^3$, which has the "runaway" solution $x = x_0 e^{t/\tau}$,²⁷ but which he dismissed (sec. 4 of [47]) as having no physical meaning (*keine Bedeutung*).

Planck's efforts to understand thermal radiation soon led him to infer that the energy of his "resonators" was quantized [55], after which he seldom discussed radiation damping (and his broader interest in "classical electron theory" also diminished with time).²⁸

14 Related Efforts around 1900

Following the "discovery" of the electron by Thomson (1897) [48] and others, interest increased in charges with high velocity.²⁹ The early effort by Thomson (1881) [25] on the fields of a charge with low velocity had been generalized to arbitrary velocity by Heaviside (1889) [32], who found that the equipotential surfaces are ellipsoids contracted by the factor $1/\sqrt{1-v^2/c^2}$ in the direction of motion. FitzGerald (1889) [33] and Lorentz (1892) [40] then argued that this implies the length of material objects in motion to be so contracted (although at the time they considered the contraction only to order v^2/c^2). This was considered to be an electromechanical effect in what we now call the (inertial) lab frame. Only in 1905 did Einstein develop the theory of special relativity [77] in which the contraction is

²⁶The logic of eq. (11) is crisp only for periodic motion.

²⁷Planck's result came shortly before J.J. Thomson [48] determined the ratio e/m for an electron, with the implication that $\tau \approx 10^{-23}$ s.

²⁸Some mention by Planck of radiation damping appears in sec. III of the 1906 edition of [83], but this was omitted in the second (1914) edition that most readers are more familiar with.

²⁹The emerging "electron theory" was the topic of the 1900 *Festschrift* for Lorentz [54]. Efforts around this time related to the question of electromagnetic mass (but not the radiation reaction) are reviewed in chap. 1 of [154].

regarded as an effect of the contraction of the spatial coordinates (along with an expansion of the time scale) of a moving (inertial) frame of reference relative to those in the lab frame.

Meanwhile, an important step was the deduction of the potentials and fields of an accelerated charge with arbitrary velocity (less than c) by Liénard (1898) [50], and by Wiechert (1900) [57]. Liénard also deduced the power radiated by an accelerated charge with high velocity, eq. (21) of [50], which was independently deduced by Heaviside (1902) [64].³⁰ These results had the implication that atoms could not be tiny “solar systems” with electrons orbiting a central positive charge, as such orbits would quickly decay via emission of radiation, which led Thomson (1903) to consider “plum pudding” models in which a sphere of positive charge at rest contained rings of moving negative charge that did not emit radiation [69, 75].³¹

The first convincing experimental evidence for the radiation pressure of light was given by Lebedev in 1901 [61], and confirmed by Nichols and Hull [62, 67].³²

15 Abraham and the Radiation Reaction at High Velocity

In the early 1900’s, Abraham followed Lorentz in considering classical models of a spherical electron, first [63] discussing the self force (for low velocity) in the manner of Lorentz, without mention of radiation.³³ Then, in 1904 [70] he began to speak of the *Strahlungsdruckes* (radiation pressure) exerted on an accelerated charge (of arbitrary velocity) as a reaction to its emission of radiation.³⁴ It seems (to this author) that his results were more clearly presented in his 1905 “textbook” [72], in which sec. 15 is titled *Die Rückwirkung der Strahlung auf ein bewegtes Elektron* (the back reaction of radiation on a moving electron). If we also translate *Rückwirkung der Strahlung* as “radiation reaction”, this would be the earliest use of that term.

³⁰Liénard discussed the self force, sec. III, p. 53 of [50], but only displayed the term that contributes to the “electromagnetic mass”.

³¹A classical electron would gain infinite kinetic energy as it spiraled in to a point nucleus (during a finite, short time), which is a type of “runaway” solution. The inclusion of Lorentz’ self force (5) in the equation of motion does not prevent this “runaway” behavior [173].

The gain in kinetic energy of the inspiraling electron is compensated by a reduction in the cross term in electric field energy of the electron and the nucleus. However, this early clue as to the importance of such cross terms seems not to have been noticed around 1900.

The gain in kinetic energy associated with the “friction” due to radiation is analogous to the “satellite paradox”, that a satellite in low-Earth orbit speeds up, and falls inwards, due to atmospheric drag [119].

³²The famous Crookes radiometer [22] does not demonstrate electromagnetic radiation pressure, as argued by Schuster [23]. See also [127].

³³For a commentary (1908) on the work of Lorentz and Abraham, see [84]. Other early commentaries include [93, 100, 101], and more recently [130, 134].

A parallel effort by Sommerfeld led to an integral form for the self force, sec. 11 of [73]. See also [74]. This work had little impact, but survives in discussions of the “memory equation” in, for example, chap. 7 of [174].

³⁴The title of a brief report from 1904 (in English) by Abraham [71] is *The Reaction of the Radiation on a Moving Electron*.

On pp. 71-73 of [72] (pp. 69-70 of the 1908 edition [86]), Abraham reviewed Planck's derivation of radiation damping [45], but without attribution.³⁵

In eqs. (77d-e), p. 111, of [72], he gave the Poynting vector [28], $\mathbf{S} = (c/4\pi)\mathbf{E} \times \mathbf{B}$, at large distances from an accelerated charge e . He then obtained the total power P_{rad} that crosses a sphere of large radius r in eq. (82), p. 118, with $\gamma = 1/\sqrt{1 - v^2/c^2}$,^{36,37}

$$P_{\text{rad}} = \frac{dU_{\text{rad}}}{dt} = \frac{2e^2\gamma^4}{3c^3} \left[\dot{\mathbf{v}}^2 + \gamma^2 \frac{(\mathbf{v} \cdot \dot{\mathbf{v}})^2}{c^2} \right]. \quad (13)$$

For \mathbf{v} , $\dot{\mathbf{v}}$ and γ at time t at the charge, the power P would be that observed at time $t_{\text{obs}} = t + r/c$, upon integration of the Poynting vector over the whole sphere.³⁸ Abraham considered that the power P comes from the energy U_e of the charge, so his eq. (83) actually had the form,

$$\frac{dU_e}{dt} = -\frac{dU_{\text{rad}}}{dt} = -P_{\text{rad}} = -\frac{2e^2\gamma^4}{3c^3} \left[\dot{\mathbf{v}}^2 + \gamma^2 \frac{(\mathbf{v} \cdot \dot{\mathbf{v}})^2}{c^2} \right]. \quad (14)$$

On pp. 107-115 of [72], Abraham established for charges with low velocity that the power P_{rad} transmitted across the large sphere is accompanied by a transmission of momentum, $d\mathbf{P}_{\text{rad}}/dt$, related by,

$$\frac{d\mathbf{P}_{\text{rad}}}{dt} = P_{\text{rad}} \frac{\mathbf{v}}{c^2} = \frac{dU_{\text{rad}}}{dt} \frac{\mathbf{v}}{c^2}. \quad (15)$$

In this he used Thomson's [41, 185] and Poincaré's [56] identification that $\mathbf{p} = \mathbf{S}/c^2$ is the density of momentum in the electromagnetic field.^{39,40} Then, for motion with arbitrary

³⁵Abraham cited Planck's paper [47] in [49] (1898). Because [72] was a "textbook" and not a research paper, Abraham may have felt it unnecessary to reference a then-well-known paper. Whatever the reason for Abraham not citing Planck, an unfortunate consequence is that most present "textbooks" also omit acknowledgment of Planck's (and Poincaré's) introduction of the notion of a damping force in reaction to radiation. Abraham associated Planck's radiation-damping force (12) with Lorentz' self force (5), perhaps giving the impression, as implied in some later textbooks, that Lorentz derived this result by the method of Planck.

As will be seen below, Abraham's derivation of the radiation damping force for charges with arbitrary velocity followed Planck, rather than Lorentz, but it is sometimes implied (as in sec. 16.3 of [169]) that Abraham used Lorentz' considerations of the self force on an extended charge in reaching his results for arbitrary velocity. However, Abraham did not reproduce Lorentz' "direct derivation" (*direktre Ableitung*) of eq. (5) in [72], but referred the reader to sec. 20 of Lorentz' 1903 article [68].

³⁶Abraham used the symbol \mathcal{X} for the quantity $\sqrt{1 - v^2/c^2} = 1/\gamma$, and wrote η as the angle between the velocity vector \mathbf{v} and the acceleration vector $\dot{\mathbf{v}}$.

³⁷The result (13) had been deduced by Liénard (1898) in eq. (21) of [50], and by Heaviside (1902) in eq. (10) of [64].

³⁸According to the "Sommerfeld condition" [95, 166], eq. (13) is the power radiated by the charge at time t . However, this interpretation is misleading, in that the power P need not have come from the charge itself, but could have come from the electromagnetic field energy associated with the charge.

³⁹Poincaré's paper [56] is cited by Abraham on p. 31 of [72]. The relation $\mathbf{p} = \mathbf{S}/c^2$ had been deduced by Abraham on pp. 124-125 of [66], then appeared just after eq. (33b), p. 273 of [70], and was given in eq. (18), p. 27 of [72].

⁴⁰A justification via special relativity of the relation (15) is given in sec. 2.2.6 of [148].

velocity, eqs. (13) and (15) lead to,

$$\frac{d\mathbf{P}_{\text{rad}}}{dt} = \frac{2e^2\gamma^4\mathbf{v}}{3c^5} \left[\dot{\mathbf{v}}^2 + \gamma^2 \frac{(\mathbf{v} \cdot \dot{\mathbf{v}})^2}{c^2} \right]. \quad (16)$$

The quantity $d\mathbf{P}_{\text{rad}}/dt$ has the dimensions of force, and Abraham argued that there should be a back reaction force on the charge given by,⁴¹

$$\mathbf{F}_{\text{rad}} = -\frac{d\mathbf{P}_{\text{rad}}}{dt} = -\frac{2e^2\gamma^4\mathbf{v}}{3c^5} \left[\dot{\mathbf{v}}^2 + \gamma^2 \frac{(\mathbf{v} \cdot \dot{\mathbf{v}})^2}{c^2} \right]. \quad (17)$$

However, the supposed reaction force (17) vanishes as velocity $v \rightarrow 0$, and does not equal Lorentz' self force (5).⁴²

In sec. 15 of [72], Abraham found a way to reconcile Lorentz' result (5) with eqs. (14) and (17), following the spirit of Planck's derivation of the radiation damping force (sec. 13 above).⁴³

Abraham supposed that the charge is accelerated only during the interval $t_1 < t < t_2$, and argued that the changes in energy and momentum of the charge in reaction to its radiation should be,

$$\Delta U = \int_{t_1}^{t_2} \frac{dU_e}{dt} dt = - \int_{t_1}^{t_2} P_{\text{rad}} dt = -\frac{2e^2}{3c^3} \int_{t_1}^{t_2} \left[\gamma^4 \dot{\mathbf{v}}^2 + \gamma^6 \frac{(\mathbf{v} \cdot \dot{\mathbf{v}})^2}{c^2} \right] dt \quad (18)$$

$$\Delta \mathbf{P} = \int_{t_1}^{t_2} \mathbf{F}_{\text{rad}} dt = - \int_{t_1}^{t_2} \frac{d\mathbf{P}_{\text{rad}}}{dt} dt = -\frac{2e^2}{3c^5} \int_{t_1}^{t_2} \left[\gamma^4 \mathbf{v} \dot{\mathbf{v}}^2 + \gamma^6 \frac{\mathbf{v}(\mathbf{v} \cdot \dot{\mathbf{v}})^2}{c^2} \right] dt. \quad (19)$$

These quantities can be related to another form, which we call the radiation damping force, $\mathbf{F}_{\text{damping}}$, by,

$$\Delta U = \int_{t_1}^{t_2} \mathbf{F}_{\text{damping}} \cdot \mathbf{v} dt, \quad \Delta \mathbf{P} = \int_{t_1}^{t_2} \mathbf{F}_{\text{damping}} dt, \quad (20)$$

which are to be obtained from eqs. (18)-(19) via integration by parts. Abraham found (sec. 15 of [72]),⁴⁴

$$\mathbf{F}_{\text{damping}} = \frac{2e^2}{3c^3} \left[\gamma^2 \ddot{\mathbf{v}} + \frac{\gamma^4 \mathbf{v}(\mathbf{v} \cdot \ddot{\mathbf{v}})}{c^2} + \frac{3\gamma^4 \dot{\mathbf{v}}(\mathbf{v} \cdot \dot{\mathbf{v}})}{c^2} + \frac{3\gamma^6 \mathbf{v}(\mathbf{v} \cdot \dot{\mathbf{v}})^2}{c^4} \right], \quad (21)$$

which equals Lorentz' form (5) when $\mathbf{v} = 0$.⁴⁵ This suggests, but does not demonstrate, that the form of eq. (21) is the desired generalization Lorentz' self force \mathbf{F}_{self} of eq. (5) to

⁴¹Equations (14) and (17) were the final results of Abraham's 1904 paper [70].

⁴²Since the quantity $d\mathbf{P}_{\text{rad}}/dt$ is related to the fields far from the charge, it is not necessarily the case that the momentum at large distances is directly related to the momentum of the accelerated charge. Indeed, in the example of a collapsing electric dipole [191], the charges gain, not lose, momentum from the field (while far from the collapsing dipole there is an outward flow of field energy. Hence, we should not expect eq. (17) to represent the radiation-reaction force on the accelerated charge.

⁴³Abraham chose to transform eq. (17) into a form like eq. (5), but he could have instead transformed eq. (5) into the form (17), as illustrated in Appendix A.

⁴⁴The details of the integrations by parts were omitted from the 2nd (1908) edition [86] of [72].

⁴⁵The result (21) was given by Abraham in eq. (12) of a brief report (in English) in 1904 [71], which he described as "the reaction of radiation on a point charge".

arbitrary velocity. Such a demonstration was provided by Abraham (1908, p. 387 of [86]) and by von Laue (1908) [89] via a Lorentz transformation of eq. (5), as reviewed in sec. 17 below, and by Schott (1912) [94] using Lorentz' argument based on retarded potentials, as reviewed in sec. 19.1 below.

Abraham noted (sec. 15 of [72]) that it is actually easier to go from eq. (20), using $\mathbf{F}_{\text{damping}}$ from eq. (21), to eqs. (18)-(19) than *vice versa*. That is,

$$\int_{t_1}^{t_2} f \dot{g} dt = fg \Big|_{t_1}^{t_2} - \int_{t_1}^{t_2} g \dot{f} dt, \quad (22)$$

$$\int_{t_1}^{t_2} \gamma^2 \ddot{\mathbf{v}} dt = \int_{t_1}^{t_2} \gamma^2 \frac{d\dot{\mathbf{v}}}{dt} dt = \gamma^2 \dot{\mathbf{v}} \Big|_{t_1}^{t_2} - \int_{t_1}^{t_2} \frac{2\gamma^4 \dot{\mathbf{v}} (\mathbf{v} \cdot \dot{\mathbf{v}})}{c^2} dt, \quad (23)$$

$$\begin{aligned} \int_{t_1}^{t_2} \frac{\gamma^4}{c^2} (\mathbf{v} \cdot \ddot{\mathbf{v}}) \mathbf{v} dt &= \int_{t_1}^{t_2} \frac{\gamma^4}{c^2} \left(\mathbf{v} \cdot \frac{d\dot{\mathbf{v}}}{dt} \right) \mathbf{v} dt = \frac{\gamma^4}{c^2} (\mathbf{v} \cdot \dot{\mathbf{v}}) \mathbf{v} \Big|_{t_1}^{t_2} \\ &\quad - \int_{t_1}^{t_2} \left[\frac{\gamma^4 \mathbf{v} \dot{\mathbf{v}}^2}{c^2} + \frac{\gamma^4 \dot{\mathbf{v}} (\mathbf{v} \cdot \dot{\mathbf{v}})}{c^2} + \frac{4\gamma^6 \mathbf{v} (\mathbf{v} \cdot \dot{\mathbf{v}})^2}{c^4} \right] dt, \end{aligned} \quad (24)$$

$$\int_{t_1}^{t_2} \left[\gamma^2 \ddot{\mathbf{v}} + \frac{\gamma^4}{c^2} (\mathbf{v} \cdot \ddot{\mathbf{v}}) \mathbf{v} \right] dt = - \int_{t_1}^{t_2} \left[\frac{\gamma^4 \mathbf{v} \dot{\mathbf{v}}^2}{c^2} + \frac{3\gamma^4 \dot{\mathbf{v}} (\mathbf{v} \cdot \dot{\mathbf{v}})}{c^2} + \frac{4\gamma^6 \mathbf{v} (\mathbf{v} \cdot \dot{\mathbf{v}})^2}{c^4} \right] dt, \quad (25)$$

Then, using eq. (25) in the time integral of eq. (21), we arrive at the rightmost form of eq. (19).

For completeness, we note that,

$$\begin{aligned} \mathbf{F}_{\text{damping}} \cdot \mathbf{v} &= \frac{2e^2}{3c^3} \left[\gamma^2 \mathbf{v} \cdot \ddot{\mathbf{v}} \left(1 + \gamma^2 \frac{v^2}{c^2} \right) + \frac{3\gamma^4 (\mathbf{v} \cdot \dot{\mathbf{v}})^2}{c^2} \left(1 + \gamma^2 \frac{v^2}{c^2} \right) \right] \\ &= \frac{2e^2}{3c^3} \left[\gamma^4 \mathbf{v} \cdot \ddot{\mathbf{v}} + \frac{3\gamma^6 (\mathbf{v} \cdot \dot{\mathbf{v}})^2}{c^2} \right]. \end{aligned} \quad (26)$$

Via a partial integration, we have that,

$$\begin{aligned} \int_{t_1}^{t_2} \gamma^2 \mathbf{v} \cdot \ddot{\mathbf{v}} dt &= \int_{t_1}^{t_2} \gamma^2 \mathbf{v} \cdot \frac{d\dot{\mathbf{v}}}{dt} dt \\ &= \gamma^2 \mathbf{v} \cdot \dot{\mathbf{v}} \Big|_{t_1}^{t_2} - \int_{t_1}^{t_2} \left[\gamma^2 \dot{\mathbf{v}}^2 + \frac{4\gamma^6 (\mathbf{v} \cdot \dot{\mathbf{v}})^2}{c^2} \right] dt, \end{aligned} \quad (27)$$

such that the time integral of $\mathbf{F}_{\text{damping}} \cdot \mathbf{v}$ equals the rightmost form of eq. (18).

Abraham achieved a significant success in arriving at eq. (21) for the radiation damping $\mathbf{F}_{\text{damping}}$ of eq. (21), but it remained somewhat unsettling that this does not equal \mathbf{F}_{rad} of eq. (17), which seemed like the proper candidate for the ‘‘radiation-reaction force’’. An insight as to how this might be physically consistent was obtained later by Schott, as discussed in sec. 19.2 below.

In 1908, p. 387 of [86], Abraham used a Lorentz transformation of Planck's damping force, eq. (5) above (eq. (58), p. 70 of [86]), in an inertial frame where the charge is instantaneously at rest, to deduce the damping force in the lab frame where the charge has velocity \mathbf{v} , finding the same form as eq. (21) for $\mathbf{F}_{\text{damping}}$.

While Plank’s argument for the radiation-damping force requires that the acceleration vanish at $t \rightarrow \pm\infty$, this is not required in Lorentz’ derivation of the self force (5). So, we infer that Abraham’s expression (21) holds even for the (mathematical) case that the charge is accelerated in both limits $t \rightarrow \pm\infty$.

16 Hadamard and Ehrenfest

We digress slightly to note that in 1908, Hadamard [87, 106] considered radiation in two spatial dimensions, finding that in the Lorentz gauge the potential $V(\mathbf{x}, t)$ is not simply a function of the charge density at \mathbf{x}' at the retarded time $t' = t - |\mathbf{x} - \mathbf{x}'|/c$, but at all earlier times as well.⁴⁶ As a consequence the form of the radiation reaction is somewhat different in two spatial dimensions than in three.

This led Ehrenfest (1917) [98, 102] to argue that this is why we live in a 3-dimensional space.

The theme of radiation, and the radiation reaction in other than three spatial dimensions is the subject of ongoing discussion, as recently reviewed in [198].

17 von Laue and the Lorentz Transformation

In 1908, von Laue [89] (still writing as M. Laue) independently used a Lorentz transformation of Lorentz’ self force \mathbf{F}_{self} (= Planck’s damping force), eq. (5), to find Abraham’s result eq. (21) for $\mathbf{F}_{\text{damping}}$.

In 1911, von Laue published a “textbook” on the theory of relativity [92] that included a section on uniformly accelerated (hyperbolic) motion (see also sec. 18 below), which ended with a footnote (p. 116): *For hyperbolic motion the self force (Zusatzkraft) $2e^2\ddot{v}/3c^3$ is zero. In this case there is no radiation in unbounded hyperbolic motion.*

18 Born and Uniformly Accelerated Motion

An example that has led to extensive discussion regarding the character of the radiation reaction is uniformly accelerated motion of an electric charge, due perhaps to a uniform external electric field. Minkowski (1909) [88] is sometimes credited for the first discussion of this example in a relativistic context, but perhaps Born (1909) [90] deserves the credit

⁴⁶See also [184, 194, 196].

here.^{47,48} The hyperbolic motion of a uniformly accelerated charge was also treated by Sommerfeld (1910) in sec. 8 of [91], who also referenced Minkowski for discussions of relativistic hyperbolae.⁴⁹

Of these works, only Born [90] mentioned the self force/radiation reaction, writing on p. 5: *Bemerkenswert ist, daß ein Elektron bei einer Hyperbelbewegung, so groß auch ihre Beschleunigung sein mag, Reine eigentliche Strahlung veranlaßt, sondern sein Feld mit sich führt, was bis jetzt nur für gleichförmig bewegte Elektronen bekannt war. Die Strahlung und der Widerstand der Strahlung treten erst bei Abweichungen von der Hyperbelbewegung auf.* This can be translated as: *It is remarkable, that an electron causes no actual radiation, as great as its acceleration may be, but it drags its field along with it, which was up to now only known for uniformly moving electrons. The radiation and the resistance of the radiation only arise at deviations from hyperbolic motion.*

Born’s is perhaps the earliest claim that a uniformly accelerated charge doesn’t “radiate” (which claim was quickly endorsed by von Laue on p. 116 of [92]).

19 Schott

The radiation reaction was the subject of the 1908 Adams Prize (Cambridge), and the winning essay, by Schott, was enlarged and published as a book in 1912 [94].

19.1 Self Force

In Appendix D of [94], Schott followed Lorentz’ method [39, 81] of computing the self force on an extended, accelerated charge, but considered the velocity \mathbf{v} to be arbitrary, and arrived (sec. 225) at the same form for \mathbf{F}_{self} as eq. (21) for Abraham’s $\mathbf{F}_{\text{damping}}$.⁵⁰ Surprisingly, Schott did not realize in [94] that the damping/self force (21) is zero for uniformly accelerated

⁴⁷Born’s solution did not contain a plane $x = -ct$ of infinite field strength, and so is better regarded as holding for a pair of equal and opposite charges at $\pm x_b$, with equal and opposite, uniform acceleration, as pointed out in [104] (see sec. 21 below). This is illustrated by the figure on p. 68 of [94], which shows the electric field lines for a positive charge at x_b , which terminate on the plane $x = -ct$, but could be mathematically extended to terminate on a negative charged at $-x_b$. Lines of the Poynting vector \mathbf{S} are also shown in the figure.

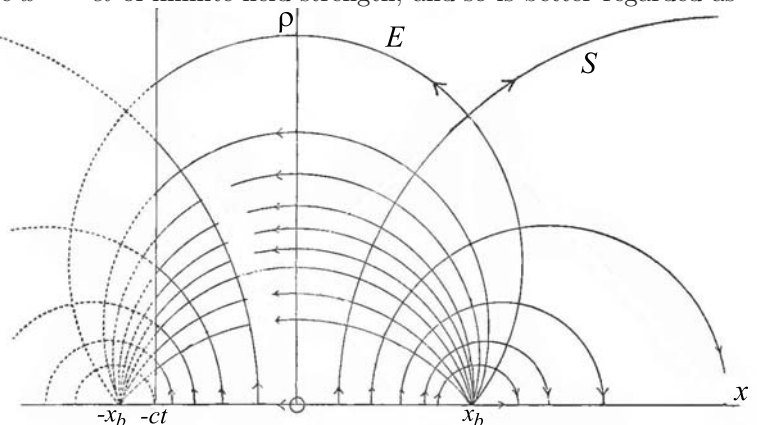

For additional discussion by the author of uniformly accelerated motion, see [187].

⁴⁸The motion of a uniformly accelerated charge is a hyperbola on a space-time diagram, which diagrams were introduced by Minkowski [88], who did consider hyperbolae on such diagrams.

⁴⁹The efforts of Minkowski and Sommerfeld related to uniformly accelerated motion are reviewed in [190].

⁵⁰The author has the impression that many people suppose Abraham [72] to have followed Lorentz’ method [39, 68, 81] (rather than that of Planck [47]), and omit giving Schott credit for being to the first to arrive at eq. (21) by Lorentz’ approach.

motion,⁵¹ as inferred from his comments on pp. 63 and 245-246. Only in sec. 8 of [96] (1915) did he remark that $F_{\text{self}} = 0$ for uniformly accelerated motion.

19.2 Uniformly Accelerated Charge and the Schott/Acceleration Energy

Schott treated the example of a charge uniformly accelerated by a constant external electric field in secs. 43-49, pp. 63-69 of [94], obtaining noteworthy results.⁵²

In secs. 145-146 and 235 of [94] he considered the power delivered $\mathbf{v} \cdot \mathbf{F}$ delivered to the charge, and identified a term proportional to the time derivative of what is now called the Schott energy,

$$U_{\text{Schott}} = -\frac{2e^2\gamma^4\mathbf{v} \cdot \dot{\mathbf{v}}}{3c^2}. \quad (28)$$

His comments in sec. 235 suggests that at the time (1912), he did not regard eq. (28) as part of the “electromagnetic energy” of the charge (which is to be “renormalized” into the its effective mass), but as somehow part of its “radiation”.

Schott continued his arguments in 1915 [96], where he noted that eq. (26) can be rewritten as,

$$\mathbf{F}_{\text{self}} \cdot \mathbf{v} = -P_{\text{rad}} - \frac{dU_{\text{Schott}}}{dt} = \frac{dU_e}{dt} - \frac{dU_{\text{Schott}}}{dt} \quad (29)$$

where $P_{\text{rad}} = -dU_e/dt$ of eqs. (15)-(16) is the power “radiated” into the far zone by the accelerated charge, and the Schott energy is given by eq. (28).

In [96], Schott defined $Q = 2e^3\gamma^4\mathbf{v} \cdot \dot{\mathbf{v}}/3c^2$, and said: *hence $-Q$ must be regarded as work stored in the electron in virtue of its acceleration, so that we may speak of it as acceleration energy*. And, at the beginning of sec. 146 of [94], Schott had said; *If we adopt the usual convention that the kinetic energy depends on the velocity only, and not on the acceleration, we must exclude the second small term (i.e., the Schott energy) from the kinetic energy, and regard it as reversible radiant energy.*

Thus, it appears that Schott did not support the idea that his “acceleration energy” could/should be “renormalized” into the energy-momentum of the charge. And, it also seems that he did not consider how, according to Liénard [50], the fields of an accelerated charge have terms proportional to the (retarded) acceleration $\dot{\mathbf{v}}$, and terms that do not involve $\dot{\mathbf{v}}$, such that the field energy and momentum, which are quadratic in the fields, contain “cross terms” proportional to the acceleration. This last theme was only explored much later, by Teitelboim [131, 132, 151], and by Eriksen and Grøn [172, 179] who identify these “cross terms” with the Schott energy/momentum, as reviewed in sec. 30 below.

In any case, Schott’s discussion of the “acceleration energy” introduced the notion that the electromagnetic energy “radiated” by a charge can come from its electromagnetic field,

⁵¹To verify this, note that if a^* is the constant acceleration in the instantaneous (inertial) rest frame of the charge, then the lab-frame acceleration is $\dot{v} = a^*/\gamma^2$, and $\ddot{v} = -3a^*v/\gamma^4c^2$.

⁵²For a review by the author of these results, see [187].

as well as flowing off the charge itself.⁵³

From Schott's description of the quantity P_{rad} (Schott's R of eq. (7) [96]), one infers that Schott considered a uniformly accelerated charge to radiate (and was unaware of the claims of Born [90] and von Laue [92] to the contrary).

Schott's result, eq. (29), gives an additional perspective on the argument of Abraham (sec. 15 above), that,

$$\int_{t_1}^{t_2} \mathbf{F}_{\text{self}} \cdot \mathbf{v} dt = \int_{t_1}^{t_2} \frac{dU_e}{dt} dt - \int_{t_1}^{t_2} \frac{dU_{\text{Schott}}}{dt} dt = \int_{t_1}^{t_2} \frac{dU_e}{dt} dt - U_{\text{Schott}} \Big|_{t_1}^{t_2} = \int_{t_1}^{t_2} \frac{dU_e}{dt} dt, \quad (30)$$

when the acceleration $\dot{\mathbf{v}}$ is nonzero only for $t_1 < t < t_2$.

19.2.1 Schott Momentum

This subsection contains results that follow from Schott's arguments, but were not deduced by him.

Schott did not remark that the self force (21) could be rewritten to include a total time derivative as,

$$\mathbf{F}_{\text{self}} = -\frac{d\mathbf{P}_{\text{rad}}}{dt} - \frac{d\mathbf{P}_{\text{Schott}}}{dt} = -\frac{P_{\text{rad}}\mathbf{v}}{c^2} - \frac{d\mathbf{P}_{\text{Schott}}}{dt}, \quad (31)$$

where the Schott momentum is defined as,

$$\mathbf{P}_{\text{Schott}} = -\frac{2e^2}{3c^3} \left(\gamma^2 \dot{\mathbf{v}} + \frac{\gamma^4 \mathbf{v} \cdot \dot{\mathbf{v}}}{c^2} \mathbf{v} \right). \quad (32)$$

The Schott energy and momentum form a 4-vector,⁵⁴

$$U_{\text{Schott}}^\mu = -\frac{2e^2}{3c^2} a^\mu = (U_{\text{Schott}}, c\mathbf{P}_{\text{Schott}}) = -\frac{2e^2}{3c^2} \left\{ \gamma^4 \mathbf{a} \cdot \frac{\mathbf{v}}{c}, \gamma^2 \mathbf{a} + \gamma^4 \left(\mathbf{a} \cdot \frac{\mathbf{v}}{c} \right) \frac{\mathbf{v}}{c} \right\}, \quad (33)$$

where we use the notation that the position 4-vector is $x^\mu = (ct, \mathbf{x})$, the velocity 4-vector is $u^\mu = dx^\mu/d\tau = \gamma dx^\mu/dt = \gamma(c, \mathbf{v})$, the acceleration 4-vector is,

$$a^\mu = \frac{du^\mu}{d\tau} = \gamma \frac{du^\mu}{dt} = \gamma \dot{\gamma}(c, \mathbf{v}) + \gamma^2(0, \dot{\mathbf{v}}) = \left(\frac{\gamma^4 \mathbf{v} \cdot \dot{\mathbf{v}}}{c}, \gamma^2 \dot{\mathbf{v}} + \frac{\gamma^4 (\mathbf{v} \cdot \dot{\mathbf{v}}) \mathbf{v}}{c^2} \right), \quad (34)$$

noting that,

$$\dot{\gamma} = \frac{\gamma^3 \mathbf{v} \cdot \dot{\mathbf{v}}}{c}, \quad (35)$$

and the metric is $(1, -1, -1, -1)$. For completeness, we record that,

$$u^\mu u_\mu = c^2, \quad a^\mu a_\mu = \frac{du^\mu}{d\tau} \frac{du_\mu}{d\tau} = -\gamma^4 \dot{\mathbf{v}}^2 - \gamma^6 \frac{(\mathbf{v} \cdot \dot{\mathbf{v}})^2}{c^2} = -\mathbf{a}^{*2}, \quad (36)$$

⁵³This phenomenon is nicely illustrated in the example of an electric dipole, initially at rest, that decays starting at, say, $t = 0$ [191]. For the case of exponential decay, see [133, 167], as well as sec. 2.5 of [177] and sec. 2.7 of [182].

⁵⁴Schott seemed skeptical of the theory of relativity, and avoided use of 4-vectors, preferring separate discussion of their space and time components.

where \mathbf{a}^* is the acceleration in the instantaneous (inertial) rest frame of the charge. Then, recalling eqs. (13) and (15), we see that the rate P_{rad} of radiated energy and momentum is a Lorentz invariant,

$$P_{\text{rad}} = \frac{dU_{\text{rad}}}{dt} = \frac{2e^2}{3c^3} \left[\gamma^4 \dot{\mathbf{v}}^2 + \frac{\gamma^6 (\mathbf{v} \cdot \dot{\mathbf{v}})^2}{c^2} \right] = -\frac{2e^2}{3c^3} a^\mu a_\mu = -\frac{2e^2}{3c^3} \frac{du^\mu}{d\tau} \frac{du_\mu}{d\tau}, \quad (37)$$

and that the quantity,

$$\frac{dU_{\text{rad}}^\mu}{d\tau} = \gamma \frac{dU_{\text{rad}}^\mu}{dt} = \frac{P_{\text{rad}} u^\mu}{c} = \gamma \left(P_{\text{rad}}, c \frac{P_{\text{rad}} \mathbf{v}}{c^2} \right) = \gamma \left(P_{\text{rad}}, c \frac{d\mathbf{P}_{\text{rad}}}{dt} \right), \quad (38)$$

is a 4-vector.

20 Page

The term “radiation reaction” was perhaps first used in English in [99] (1917, which is otherwise not particularly noteworthy). A review of various other terms associated with this topic is given in sec. 2.5 of [1].

21 Milner

In 1920, Milner [104] commented that the singular behavior on the plane $x = -ct$ for a uniformly accelerated charge along the x -axis is not present if the system consists of a pair of uniformly accelerated charges, q and $-q$ at positions x and $-x$ (without mention of Born [90]). Milner also noted that if the Poynting vector is integrated over a sphere surrounding a uniformly accelerated charge q , the power is exactly that given by the Larmor formula [46], $P = 2q^2 a^{*2}/3c^3$, which *apparently verifies the presence of radiation in the solution*.

22 Pauli

In his treatise on the theory of relativity (1921) [103], Pauli (age 21) discussed the hyperbolic motion of a uniformly accelerated charge in sec. 32(γ) (pp. 92-93 of the English edition) and the radiation reaction in sec. 32(ζ) (p. 99 of the English edition).

He noted in his eq. (250) of sec. 32(γ) that the magnetic field is everywhere zero at the time when the charge is instantaneously at rest in the lab frame, which he considered as evidence that there is no radiation associated with this example.

In sec. 32(ζ) he presented what may be the first description of the radiation reaction in covariant notation, and gave a more compact version of Abraham’s [86] and von Laue’s [89] relativistic generalization of Lorentz’ nonrelativistic form (5) [39]. He sought a 4-force $F_{\text{self}}^\mu = \gamma(\mathbf{F}_{\text{self}} \cdot \mathbf{v}/c, \mathbf{F}_{\text{self}})$ (for which the relation $F_{\text{self}}^\mu u_\mu = 0$ is an identity). Since,

$$\begin{aligned} \frac{d^2 u^\mu}{d\tau^2} &= \left(\frac{\gamma^5 \mathbf{v} \cdot \ddot{\mathbf{v}}}{c} + \frac{\gamma^5 \dot{\mathbf{v}}^2}{c} + \frac{4\gamma^7 (\mathbf{v} \cdot \dot{\mathbf{v}})^2}{c^3}, \right. \\ &\quad \left. \gamma^3 \ddot{\mathbf{v}} + \frac{\gamma^5 \mathbf{v}(\mathbf{v} \cdot \ddot{\mathbf{v}})}{c^2} + \frac{\gamma^5 \mathbf{v} \dot{\mathbf{v}}^2}{c^2} + \frac{3\gamma^5 \dot{\mathbf{v}}(\mathbf{v} \cdot \dot{\mathbf{v}})}{c^2} + \frac{4\gamma^7 \mathbf{v}(\mathbf{v} \cdot \dot{\mathbf{v}})^2}{c^4} \right), \end{aligned} \quad (39)$$

which reduces to $(0, \ddot{\mathbf{v}})$ for $\mathbf{v} = 0$, Pauli argued that the self 4-force could be written as,

$$F_{\text{self}}^\mu = \frac{2e^2}{3c^3} \left(\frac{d^2 u^\mu}{d\tau^2} + \alpha u^\mu \right). \quad (40)$$

The requirement that $F_{\text{self}}^\mu u_\mu = 0$ implies that,

$$\alpha = -\frac{1}{c^2} u_\mu \frac{d^2 u^\mu}{d\tau^2} = \frac{1}{c^2} \frac{du^\mu}{d\tau} \frac{du_\mu}{d\tau} = -\frac{P_{\text{rad}}}{c^2}, \quad (41)$$

using eqs. (36), (37) and (39). Then, also using eq. (38),⁵⁵

$$F_{\text{self}}^\mu = \frac{2e^2}{3c^2} \frac{d^2 u^\mu}{d\tau^2} - P_{\text{rad}} \frac{u^\mu}{c^2} = -\frac{d}{d\tau} \left(-\frac{2e^2}{3c^2} \frac{du^\mu}{d\tau} \right) - P_{\text{rad}} \frac{u^\mu}{c^2} = -\frac{dU_{\text{Schott}}^\mu}{d\tau} - \frac{dU_{\text{rad}}^\mu}{d\tau}. \quad (42)$$

The time component of this is eq. (29), and the spatial components are eq. (31).

Pauli's derivation starts from Lorentz' self force (5), originally deduced without consideration of radiation, and quickly arrives at the form (42) in which a relation to radiation can be seen. This reinforces the now-common description of the self force as the radiation-reaction force.

Pauli also noted that the self force (42) vanishes for uniformly accelerated motion, which he considered to confirm his conclusion in sec. 32(γ) that there is no radiation in this case.

If Pauli had extended his very compact discussion to include the equation of motion for the electric charge, it would have read,

$$m \frac{du^\mu}{d\tau} = F_{\text{ext}}^\mu + F_{\text{self}}^\mu = eF_{\text{ext}}^{\mu\nu} u_\nu - \frac{dU_{\text{Schott}}^\mu}{d\tau} - \frac{dU_{\text{rad}}^\mu}{d\tau} = eF_{\text{ext}}^{\mu\nu} u_\nu + \frac{2e^2}{3c^2} \frac{d^2 u^\mu}{d\tau^2} - \frac{P_{\text{rad}} u^\mu}{c^2}, \quad (43)$$

where $F_{\text{ext}}^{\mu\nu}$ is the electromagnetic field 4-tensor, supposing the external force to be electromagnetic.

23 Compton and a Reaction to Quantum Radiation

In 1922, Compton [105] provided evidence that the wavelength of energetic x-rays is decreased when they scatter off an electron initially at rest. This contrasts with classical scattering of (optical) light by electrons, perhaps first analyzed by J.J. Thomson in secs. 161-163 of [82], in which the frequency of the light is unchanged by scattering off a charge at rest.⁵⁶

⁵⁵To this author, Pauli's argument leading to eq. (42) is identical to that given in sec. 76 of [143] by Landau and Lifshitz, but the latter are sometimes credited with a new/independent derivation. Section 75 of [143] arrives at the nonrelativistic result (5) via an argument that is essentially the same as Planck's [47].

⁵⁶Lord Rayleigh analyzed the scattering of light without change in frequency off particles in the sky starting in 1871, first in an æther theory of light [15, 16] and later in Maxwell's theory [26, 53], with a goal of explaining why the sky is blue. See also [153].

23.1 Thomson Scattering

We first quickly review Thomson scattering of low-intensity light.

The acceleration of a free electron of charge e and mass m in a plane electromagnetic wave with electric field $\mathbf{E} = E_0 e^{i(kz - \omega t)} \hat{\mathbf{x}}$ is $\mathbf{a} = \dot{\mathbf{v}} = \mathbf{F}_E/m = e\mathbf{E}/m$, if the field strength is low enough that we can ignore the Lorentz force, $e\mathbf{v}/c \times \mathbf{B}$,⁵⁷ (and the radiation-reaction force). Then, the time derivative of the acceleration is $\dot{\mathbf{v}} = -i\omega\mathbf{F}_E/m$, so the ratio of the radiation-reaction force (5) on an electron to that due to the incident wave has magnitude,

$$\frac{F_{\text{radreact}}}{F_E} = \frac{2e^2\omega}{3mc^3} = \frac{2r_e}{3\lambda} \approx 10^{-9}, \quad (44)$$

where $r_e = e^2/mc^2 = 2.8 \times 10^{-15}$ m is the classical electron radius, and $\lambda = c/\omega = \lambda/\pi \approx 10^{-6}$ m for optical light. Thus, the radiation reaction is negligible in “ordinary” Thomson scattering.⁵⁸

23.2 Compton Scattering

In Compton scattering of a photon of angular frequency ω off an electron initially at rest, the scattered photon has the minimal angular frequency ω'_{min} , and the final-state electron has maximal kinetic energy KE'_{max} , for 180° backscattering,

$$\omega'_{\text{min}} = \frac{\omega}{1 + 2\hbar\omega/mc^2}, \quad \text{KE}'_{\text{max}} = \hbar\omega \frac{2\hbar\omega/mc^2}{1 + 2\hbar\omega/mc^2}. \quad (45)$$

The quantum scattering process can be thought of as due to acceleration of the electron by the incident photon, followed by radiation of the final-state photon. The gain of kinetic energy (and of momentum) by the electron during the scattering process can be thought of as a reaction to the radiation of the quantum of energy $\hbar\omega'$.

In this sense, there is a quantum radiation reaction that is very straightforward compared to the classical radiation reaction, which is associated with the self force on an accelerated charge.⁵⁹ This quantum radiation reaction is akin to the force \mathbf{F}_{rad} of eq. (17) above, as considered by Abraham [72].

⁵⁷Since $E = B$ for a plane wave, the Lorentz force is negligible if $v/c \ll 1$. If this is true, then the velocity has magnitude $a/\omega = eE_0/m\omega$, and $v/c = eE_0/m\omega c \equiv \eta \ll 1$, where η is the dimensionless measure of the electric field strength of a wave. Only extremely high-power laser beams can lead to $v \approx c$ ($\eta \gtrsim 1$) when incident on electrons, so it is a very good approximation to ignore the Lorentz force in the Thomson scattering of “ordinary” light.

⁵⁸For completeness, we note that the time-average power radiated by the electron in Thomson scattering is $\langle P_{\text{rad}} \rangle = 2e^2 \langle a^2 \rangle / 3c^3 = e^4 E_0^2 / 3m^2 c^3$, using the Larmor formula, so the scattering cross-section is $\sigma_{\text{Thomson}} = \langle P_{\text{rad}} \rangle / \langle S_E \rangle = P_{\text{rad}} / (cE_0^2 / 8\pi) = 8\pi r_e^2 / 3$.

⁵⁹There exists a literature on the “quantum radiation reaction”, which seems (to this author) to consider the effect of quantum fluctuations in the emission of photons by charged particles on a quasiclassical trajectory. See, for example [183].

24 Dirac

In 1938, Dirac [111] published a paper that purported to arrive at the equation of motion of a classical electron with no assumptions as to its structure,⁶⁰ arriving at (p. 155) *the same as the equations of-motion obtained from the Lorentz theory of the extended electron by equating the total force on the electron to zero, if one neglects terms involving higher derivatives of \mathbf{v} than the second. But whereas these equations, as derived from the Lorentz theory-, are only approximate, we now see that there is good reason for believing them to be exact, within the limits of the classical theory.*⁶¹

As we have seen, the derivation of these equations of motion by Abraham/von Laue/Pauli [72, 89, 103] followed the spirit of Planck [47], which also makes no assumptions as to the structure of the electron. Among Dirac’s few references is the paper of Schott [96], that can be said to follow Lorentz [39] in using a model of an extended charge to deduce the self force thereon.

In any case, Dirac’s derivation was somewhat different from its predecessors, such that one now often reads of eq. (43) above, Dirac’s eq. (24), as the Lorentz-Dirac or Lorentz-Abraham-Dirac equation of motion.

Dirac did not use the terms “self force” or “radiation reaction” in his paper, although he did speak of “radiation damping” (Planck’s term).⁶²

25 Eliezer and Landau

It was mentioned at the end of sec. 12 above that Lorentz considered his self force (5) to be only an approximation, valid if the motion of the charge is not too abrupt. This theme was little considered by others until 1948 when independently Eliezer [115] and Landau (p. 235 of the second, Russian edition of [143]) considered Lorentz’ *caveat* to mean that the self force must be small compared to the external force (due to electromagnetic fields).

In consequence, the self force (42) is slightly different from that found by Abraham [72] (and affirmed by von Laue [89], by Pauli [103], and in eq. (76.2) of [143]), and is better approximated by eq. (52) of [115] or eq. (76.3) of [143],

$$F_{\text{self}}^{\mu} = \frac{2e^2}{3mc^3} u_{\nu} u^{\lambda} \frac{\partial F_{\text{ext}}^{\mu\nu}}{\partial x^{\mu}} - \frac{2e^4}{3mc^5} F_{\text{ext}}^{\mu\nu} F_{\text{ext},\lambda\nu} u^{\lambda} + \frac{2e^4}{3mc^5} u^{\mu} F_{\text{ext}}^{\nu\lambda} u_{\lambda} F_{\text{ext},\lambda\kappa} u^{\kappa}. \quad (\text{Landau}). \quad (46)$$

This self force, which as anticipated by Lorentz cannot be too strong, avoids the mathematical “runaway” solutions that can be associated with the Abraham-Pauli-Dirac equation of motion.⁶³

⁶⁰Dirac did assume that the Poincaré stresses could be ignored, which issue is reviewed in Appendix B.

⁶¹Dirac expanded on this theme (in French) [112], which acknowledged an influence by Wentzel [109].

⁶²In 1941, Dirac noted [114] that difficulties with the self energy of an electron remain in quantum electrodynamics, and he considered how negative-energy photon states might mitigate this issue.

⁶³Neither Eliezer nor Landau (nor most subsequent authors) seem to have considered what is meant by the self force/radiation reaction not being too strong. So, we transcribe in Appendix C some discussion by the author on this theme, also given in [1].

The prescription (46) for modifying the self force (42) is not unique, and papers continue to be written advocating variants of eq. (46). See, for example, [138, 146, 165, 171, 178]; for a review, see [186].

*Among the vast number of papers on the theme of the “radiation reaction” since 1950, I restrict my further comments to those of five (sets of) authors.*⁶⁴

26 Fulton and Rohrlich

26.1 Uniform Acceleration and the Equivalence Principle

In 1960, Fulton and Rohrlich published a paper [121] in which they affirmed Schott’s view that a uniformly accelerated charge does “radiate,” despite the fact that the self force/radiation reaction is zero. Then, they addressed an interesting issue raised by Bondi and Gold, sec. 6 of [118]), as to whether a charge at rest in a gravitational field radiates, as would be inferred from the principle of equivalence.

To clarify this conundrum, Fulton and Rohrlich noted that one should distinguish four configurations of charge and observer in the case of zero gravity, and four equivalent configurations in the case of, say, an idealized uniform gravitational field. For zero gravity, these cases are:

1. The charge is accelerating and the observer is at rest (in the inertial lab frame).
2. The charge is at rest and the observer is accelerating.
3. Both the charge and the observer are at rest.
4. Both the charge and the observer are accelerating, in the same manner.

Fulton and Rohrlich argued that the observer detects “radiation” in cases 1 and 2, but not in cases 3 and 4.

When considering gravity, one should recall that a free-falling observer is the equivalent to an observer in an inertial frame with zero gravity. Then, the four cases with gravity are:

- 1'. The charge is at rest (with respect to the source of the static gravitational field) and the observer is free falling.
- 2'. The charge is free falling and the observer is at rest.
- 3'. Both the charge and the observer are free falling.
- 4'. Both the charge and the observer are at rest.

⁶⁴A very recent result [197] is that the self force of a (classical) point charge in rectilinear motion has been verified to be eq. (21), by computing the negative of the time rate of change of the momentum of its retarded self-field.

Case n' is the gravitational equivalent of case n in zero gravity.

The observer detects radiation in cases 1' and 2', but not in cases 3' or 4'.

A lesson is that while there is an invariant rate of radiation, eq. (37), for observers in different inertial frames, that rate is not invariant for transformations to accelerated frames.⁶⁵ In the language of quantum physics, virtual photons in an inertial frame can be “real” to accelerated observers, as later discussed by Hawking [139] and Unruh [145].⁶⁶

26.2 Where Does the Radiated Energy Come From?

In 1961, Rohrlich [123] followed Milner [104] and Schild [120] in arguing that the integral of the Poynting vector, $\int \mathbf{S}(t + r/c) \cdot d\mathbf{Area}$, over a large surface surrounding an accelerated charge, where r is the distance from the present position of the charge to a surface element, is the same as that over any sphere centered on a retarded position of the center of the charge, and which completely encloses the charge at the present time t . Rohrlich concluded that if we call the integral of a very large surface the “radiation”, in accordance with the Sommerfeld criterion [95], then we are also justified in saying that this “radiation” existed at the surface of any of the smaller spheres, considered above, as well.

26.3 Should the Schott Energy-Momentum Be “Renormalized” Away

In 1961, Rohrlich did not make (but could have) the inference that the result of sec. 26.2 implies the Schott energy resides inside these smaller spheres, and in particular, inside the smallest sphere centered on a retarded position of the center of the charge, and which completely encloses the charge at the present time t . Rather, this conclusion was only made in 2000, in paper III of [172], as reviewed in sec. 30 below.

If the charge is considered to be a point, then the Schott energy-momentum also resides at that point; only for a charge of nonzero spatial extent does the Schott energy-momentum occupy a (slightly) different volume from that of the charge itself.

In the case of an electron, the Schott energy-momentum will never be identified by experiment as distinct from the energy-momentum of the charge. Hence, it seems reasonable to follow Thomson [25] and Lorentz [39] and rewrite the equation of motion (43) as,

$$\frac{d}{d\tau}(m u^\mu + U_{\text{Schott}}^\mu) = \frac{d}{d\tau} \left(m u^\mu - \frac{2e^2}{3c^2} \frac{du^\mu}{d\tau} \right) = F_{\text{ext}}^\mu + F_{\text{rad}}^\mu = e F_{\text{ext}}^{\mu\nu} u_\nu - \frac{P_{\text{rad}} u^\mu}{c^2}, \quad (47)$$

which suggest that we “renormalize” the 4-vector $m u^\mu + U_{\text{Schott}}^\mu$ into the “mechanical” energy-momentum p^μ of an electron. If we did so, the (classical) differential equation of motion of the electron would be second order, and all debate over possible mathematically ill-behaved solutions to eq. (43) would be moot.

Advocates of a classical electron theory seem not to take this step, perhaps because $\mathbf{F}_{\text{rad}} \cdot \mathbf{v}$ does not equal the radiated power P_{rad} , as noted by Abraham [72]. In any case, while Rohrlich considered doing this, in eq. (6.7) of [122], he did not recommend it. For example,

⁶⁵Among many subsequent commentaries on this theme, see, for example, [150, 175].

⁶⁶For comments by the author on Hawking-Unruh radiation, see [168].

in his review of 2000 [170], he reverted to advocacy of the Abraham-Pauli equation of motion (43), calling this the LAD (Lorentz-Abraham-Dirac) equation.⁶⁷

Another reason not to “renormalize” the Schott energy-momentum into the “mechanical” energy-momentum p^μ is that doing so would imply that $p^2 = p^\mu p_\mu$ is not an invariant, but depends on the (invariant) acceleration $a = \sqrt{a^\mu a_\mu}$ of the electron.

27 Coleman

In 1961, Coleman wrote an unpublished note [124] for the Rand Corporation titled *Classical Electron Theory from a Modern Standpoint*. He took the view (shared by this author) that attempts to discuss the structure of the electron within the context of classical electrodynamics are “pointless”. However, he did salute Lorentz [39] for “renormalizing” the self-field energy of an electron into its mass, while remarking that it is better to think of the “bare” mass of an electron as $-\infty$ rather than zero as was argued by Lorentz in [81].

28 Does the Quantum Radiation Reaction “Cause” Spontaneous Emission?

Beginning in 1973, several authors [135]-[162] have argued that spontaneous emission of light by excited atoms is “caused” partly by quantum vacuum fluctuations and partly by the quantum “radiation reaction”. This view is an extension of an argument by Weisskopf and others [110, 116, 152] that spontaneous emission is not spontaneous, but is “caused” by vacuum fluctuations. Such views follow Einstein’s comment that “God does not play dice”, which denies that random phenomena occur in the quantum realm.

The notion that the “radiation reaction” “causes” radiation seems at odds with the usual meaning of “radiation reaction”, and such usage is not widespread. Indeed, the interpretation of spontaneous emission as partly due to the “radiation reaction” depends on the choice of ordering of certain commuting operators [157, 161].⁶⁸

29 Gordeyev

In 1975, Gordeyev [142] deduced the damping/self force (26) from an expansion of the fields of an accelerated charge in terms of present, rather than retarded, quantities.

⁶⁷In papers that followed Rohrlich’s 1961 argument, Teitelboim [151, 131, 132] also could not bring himself to recommend “renormalizing” the Schott energy-momentum into the “mechanical” energy-momentum.

⁶⁸An argument in favor of this interpretation is that a famous question, *Why isn’t an atom in its ground state (in an inertial frame) excited by vacuum fluctuations*, has an answer that for this case the effect of the quantum fluctuations is canceled by the effect of the “radiation reaction” [155]. In this view, the quantum “radiation reaction” can either “cause” or “prevent” radiation, which reinforces that this quantum usage is somewhat removed from its classical origin.

30 Eriksen and Grøn

Eriksen and Grøn discussed uniformly accelerated motion in great detail in a series of papers [172] from 2000 to 2004. Here, we emphasize their discussion of the fields and Poynting vector of an charge in arbitrary motion, section III of paper III [172].

Writing the fields as $\mathbf{E} = \mathbf{E}_{\text{nonrad}} + \mathbf{E}_{\text{rad}}$, where the “radiation” fields fall off with (retarded) distance from the charge as $1/r$, the field energy and momentum can each be written with three integrals as,

$$U_{E,\text{field}} = \int \frac{\mathbf{E}_{\text{nonrad}}^2}{8\pi} d\text{Vol} + \int \frac{\mathbf{E}_{\text{rad}}^2}{8\pi} d\text{Vol} + \int \frac{\mathbf{E}_{\text{nonrad}} \cdot \mathbf{E}_{\text{rad}}}{4\pi} d\text{Vol}, \quad (48)$$

$$\begin{aligned} \mathbf{P}_{\text{field}} = & \int \frac{\mathbf{E}_{\text{nonrad}} \times \mathbf{B}_{\text{nonrad}}}{4\pi c} d\text{Vol} + \int \frac{\mathbf{E}_{\text{rad}} \times \mathbf{B}_{\text{rad}}}{4\pi c} d\text{Vol} \\ & + \int \frac{\mathbf{E}_{\text{nonrad}} \times \mathbf{B}_{\text{rad}} + \mathbf{E}_{\text{rad}} \times \mathbf{B}_{\text{nonrad}}}{4\pi c} d\text{Vol}. \end{aligned} \quad (49)$$

Eriksen and Grøn followed the lead of Lorentz in absorbing (“renormalizing”) the terms that involve only the “nonradiation” fields into the “mechanical” energy and momentum of the charge. The terms involving only the “radiation” fields form a 4-vector (as previously noted by Fulton and Rohrlich [121] among others). And, the cross terms involving both “radiation” and “nonradiation” fields turn out to be exactly the Schott energy-momentum of eq. (33).

This last result validates the insight of Schott [96] that there exists an “acceleration energy” in the electromagnetic fields (other than the radiated energy, which also depends on the acceleration). Furthermore, Eriksen and Grøn were able to show, sec. 6, paper IV of [172], that for a model of the charge as a small sphere in its rest frame, which appears as a Lorentz-contracted ellipsoid in the lab frame, the Schott energy resides inside the smallest sphere centered on the various retarded positions of the center of the charge such that the sphere completely encloses the charge at its present position.

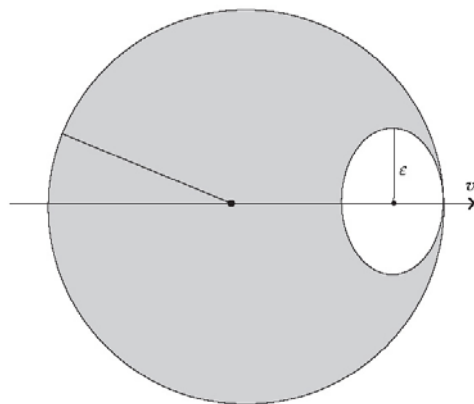

That is, an observer outside this sphere could/should consider that the “radiation” which he detects flows from inside this sphere, but not directly off the charge itself.

Since the Schott energy-momentum is localized so close to the charge (inside its Compton wavelength), it would seem reasonable to “renormalize” the Schott energy-momentum into the “mechanical” energy-momentum of the charge. Then, the Abraham-Pauli equation of motion

(43) would simplify to,

$$\frac{d}{d\tau}(m_{\text{eff}} u^\mu) = F_{\text{ext}}^\mu + F_{\text{rad}}^\mu = eF_{\text{ext}}^{\mu\nu}u_\nu - \frac{P_{\text{rad}}u^\mu}{c^2}, \quad (50)$$

and a century of debate over eq. (43) would become largely irrelevant.

These results were summarized in a pedagogic paper by Grøn [179], but he also could not bring himself to recommend “renormalizing” the Schott energy-momentum into the “mechanical” energy-momentum, as in eq. (50).

31 A Recent Experiment

We noted earlier that while the radiation reaction for oscillating currents has clear manifestation in the so-called radiation resistance of antennas, there is no experimental evidence for the classical radiation reaction of an individual electric charge. A recent proposal [189] is that such evidence might be obtained in the spectrum of radiation emitted by electrons “channeling” through a crystal. This spectrum is to be reconstructed from measurements of individual photons of GeV energy, so the proposed experiment is on the border between the classical and quantum regimes.

A recent report [192] claims evidence for deviations in the photon spectrum from predictions based on classical analysis without the radiation reaction, but the results are not in crisp agreement with a calculation that includes the classical radiation reaction, perhaps indicating that the experiment is more in the quantum realm. See also [193, 195].⁶⁹

32 Summary

1. The notion of a reaction to the emission of light was discussed qualitatively by Stewart in 1871 [17], who did not relate light to electromagnetic waves.
2. The force on oscillating electric charge in reaction to its emission of electromagnetic radiation was first discussed qualitatively by Poincaré in 1891 [38], and quantitatively by Planck in 1896 [47]. Planck seemed unaware that his result was identical to the self force on a (slow-moving) extended electric charge deduced by Lorentz in 1892 [39] without mention of radiation.
3. Planck’s argument was applied to antennas by Abraham in 1898 [49], which eventually led to the concept of the “radiation resistance” of an antenna, which for the case of an oscillatory current equals twice the time-average radiated power divided by the square of the peak current at the antenna terminals. This remains the most “practical” application of the concept of a “radiation reaction”.
4. Planck’s argument was also extended by Abraham in 1905 [72] for a single electric charge of arbitrary velocity that has nonzero acceleration over only a finite time interval. This argument assumed that the electron was a “point” charge in that it used the

⁶⁹For reviews of the radiation reaction in quantum electrodynamics, see, for example, [199, 200].

Liénard-Wiechert fields [50, 57] to deduce that total power radiated (into the far zone) by an accelerated charge. Abraham’s result, eq. (21), for the “radiation reaction” force contains a term that is the reaction to the momentum radiated by the charge, plus an additional term (often called the “Schott term”) that has become the subject of much debate (confusion) in subsequent discussions.

5. Separately, Abraham [66, 70, 72] discussed models of extended electric charges with low velocity, but he made no attempt to deduce the self force on such a charge with arbitrary velocity in the manner of Lorentz [39]. Of course, his generalization of Planck’s argument [47] on the radiation damping/reaction force can be also considered as a generalization of Lorentz’ result for the self force (since the results of Lorentz and Planck were the same, although their arguments were quite different).
6. In 1908, Abraham [86] and Von Laue [89] used a Lorentz transformation of the form (5) of Lorentz [39] and Planck [47] for the self/radiation-reaction force of a charge with arbitrary velocity, arriving at eq. (21) as previously found by Abraham [72] via a “prerelativistic” argument.
7. In 1912, Schott [94] extended Lorentz’ deduction of the self force on an extended charge to the case of arbitrary velocity, arriving at the forms previously displayed by Abraham [72] and von Laue [89] for the radiation-reaction force.⁷⁰ In 1915, Schott [96] identified the term, other than the back reaction to the radiated momentum, in Abraham’s result (21) as the time derivative on an energy, called the “acceleration energy” by Schott (and the “Schott energy” in subsequent discussions).
8. In 1921, Pauli [103] gave a covariant version of Abraham/von Laue’s argument (which can be regarded as an extension of both Lorentz’ argument [39] and that of Planck [47] for eq. (5), and identified an energy-momentum 4-vector now called the Schott 4-vector. Pauli’s argument was later transcribed by Landau and Lifshitz [143], who are often given credit for it.
9. In 1938, Dirac [111] gave an argument, nominally independent of any assumption as to the structure of a charge, for the “relativistic radiation-reaction” force first deduced by Abraham [72] (whose argument, following that of Planck [47] can be regarded as applying to a “point” charge).
10. Lorentz’ remark in sec. 37 of [81] that (in effect) the self force must not be stronger than the external force leads, together with an awareness of Planck’s quantum constant \hbar , to an understanding of limits to the domain of applicability of classical models of charged particles.
11. In 1960, Fulton and Rohrlich [121] resolved a paradox as to the relation between the radiation by (and the “radiation reaction” on) an accelerated charge and one at rest in a gravitational field.

⁷⁰Abraham, rather than Schott, is sometimes credited with having so extended Lorentz’ argument.

12. In 1961, Coleman [124] wrote a report on “Classical Electron Theory from a Modern Standpoint”, that remains more “modern” than most subsequent “classical” discussions of this topic.
13. In 2000-2002, Eriksen and Grøn [172] showed that the Schott energy-momentum 4-vector equals the cross terms between the “radiation” and “nonradiation” fields in the energy and momentum of an accelerated charge, and demonstrated that this 4-vector is localized in a small sphere that surrounds the charge.

If this energy-momentum were “renormalized” into the “mechanical” energy momentum of the charge, as in eq. (50), then the topic of the “radiation reaction” would cease to be a “perpetual problem”. That is, after “renormalizing” away the Schott energy-momentum, (almost) all that is left of the story is Planck’s view (inspired by Poincaré, and before he performed his famous integration by parts) that there is a force on an accelerated charge in reaction to its radiated momentum.⁷¹

32.1 Summary of the Summary

The most practical aspect of the radiation reaction is the radiation damping of sources (antennas) of electromagnetic radiation, as first anticipated by Poincaré in 1891 [38, 42], shortly after Hertz’ experimental generation of electromagnetic waves [31]. In the circuit analysis of an antenna, one should include the radiation resistance of the antenna, in addition to its Ohmic resistance, to account for the radiation of energy by the circuit.⁷² For this, one simply relates the time-average radiated power $\langle P \rangle$ to the peak current I_0 at the antenna terminals according to $\langle P \rangle = I_0^2 R_{\text{rad}}/2$, to deduce the radiation resistance R_{rad} .

Concurrently with the thoughts of Poincaré and others about antennas, a theory of charged particles/electrons was being developed, that is now called “classical electron theory”. In this theory, charged particles had small but finite size, although it was often convenient to consider them to be point particles, as in the famous deductions by Liénard [50] and Wiechert [57] of the electromagnetic fields of an accelerated point charge. Independent arguments by Lorentz [39] and Planck [47] led to the notion of a self force/radiation reaction on an accelerated charge proportional to the time derivative of its acceleration. Such a force does not fit well into Newton’s vision that $\mathbf{F} = m\mathbf{a}$, nominally a second-order differential equation, and leads to difficulties that have exercised the proponents of classical electron theory ever since.

⁷¹There remains the entertaining details of the case of a charge in a uniform external electric field, for which the equation of motion can be solved exactly if one supposes that Abraham’s self force appears in the equation of motion, since this happens to be zero. Whereas, in the view that the Schott terms are “renormalized” away, there would be a nonzero “radiation reaction” force which spoils the analytic integrability of the equations of motion (with little practical impact on the results, as noted by Schott in his 1912 book [94] where he argued that the radiation reaction is negligible, if not identically zero).

⁷²Heaviside, whose career began with analyses of telegraphy, considered such radiation to be a “waste” [64].

Appendix A: From Lorentz' Self Force to the Radiation Reaction

Historically, Lorentz [39] deduced eq. (1),

$$\mathbf{F}_{\text{self}} = \frac{2e^3 \ddot{\mathbf{v}}}{3c^3} \quad (1)$$

by consideration of the self force on an extended, accelerated charge distribution with low velocity. Then, apparently independently, Planck [47] considered a radiation damping/reaction force, and also arrived at eq. (5) after a clever integration by parts of the power supplied by the damping force. Here, we indicate how one might go from Lorentz' self force to a radiation-reaction force by inverting the logic of Planck's (and Abraham's [72]) argument.

We suppose that the acceleration $\dot{\mathbf{v}}$ is nonzero only for $t_1 < t < t_2$, and consider the time integral of the power supplied to the charge by Lorentz' self force, and integrate this by parts,

$$W = \int_{t_1}^{t_2} \mathbf{F}_{\text{self}} \cdot \mathbf{v} dt = \frac{2e^3}{3c^3} \int_{t_1}^{t_2} \ddot{\mathbf{v}} \cdot \mathbf{v} dt = \frac{2e^3}{3c^3} \dot{\mathbf{v}} \cdot \mathbf{v} \Big|_{t_1}^{t_2} - \frac{2e^3}{3c^3} \int_{t_1}^{t_2} \dot{\mathbf{v}}^2 dt = - \int_{t_1}^{t_2} \frac{dU_{\text{rad}}}{dt} dt, \quad (51)$$

where,

$$\frac{dU_{\text{rad}}}{dt} = \frac{2e^3 \dot{\mathbf{v}}^2}{3c^3} \quad (52)$$

is the power radiated by a (low velocity) accelerated charge, according to Larmor [46].

This establishes that the self force (1) as being a kind of reaction to radiation, but does not yet identify a ‘‘radiation reaction’’ force. For this, we might follow Einstein [78] and identify U_{rad}/c^2 as a kind of effective mass, with the implication that an accelerated charge with velocity \mathbf{v} radiates momentum at the rate,

$$\frac{d\mathbf{P}_{\text{rad}}}{dt} = \frac{dU_{\text{rad}}}{dt} \frac{\mathbf{v}}{c^2}. \quad (53)$$

As mentioned in sec. 15 above, this result was first deduced by Abraham [72] via a prerelativistic argument, and extended by him to charges with arbitrary velocity with the result given in eq. (16). Then, we arrive at the radiation-reaction force as having the form,

$$\mathbf{F}_{\text{rad}} = - \frac{d\mathbf{P}_{\text{rad}}}{dt} = - \frac{dU_{\text{rad}}}{dt} \frac{\mathbf{v}}{c^2}. \quad (54)$$

This form actually holds for arbitrary velocity if we use the general expression (13) for dU_{rad}/dt , rather than the low-velocity Larmor formula (52).

While the above argument is suggestive, it suffers from the defect that the power supplied to the charge by \mathbf{F}_{rad} is $\mathbf{F}_{\text{rad}} \cdot \mathbf{v} = -(\mathbf{v}^2/c^2) dU_{\text{rad}}/dt$ and not $-dU_{\text{rad}}/dt$ as desired. This defect likely motivated Planck and Abraham to pursue the paths that they did, in which \mathbf{F}_{rad} alone was not identified with the force in reaction to the radiation.

Appendix B: Can the Poincaré Stresses Be Ignored in the Equation of Motion of an Electron?

Written Jan. 9, 2020, this Appendix was inspired by sec. 1 of [197].

Much of the literature of the radiation reaction is in the context of the vision that electromagnetism is the only relevant interaction, with gravity being neglected, despite the evidence of additional basic interactions that emerged in the late 1890's, characterized by Rutherford [52] as associated with α and β rays. An exception was Poincaré's comment that a charged particle cannot be stable unless it involves some nonelectromagnetic interaction [79, 80]. Perhaps because the Poincaré stresses were interpreted by many as a "mechanical" effect, which would not exert a self force, the possibility of nonelectromagnetic effects in considerations of the radiation reaction have been largely ignored.

Following a discussion in [197] of the self force based on field momentum (which built on considerations of Abraham [72]) we present an argument that there must be some nonelectromagnetic contribution to the self force on an accelerated, charged particle.

We begin by supposing that the momentum of a particle of electric charge e can be expressed as the sum of "mechanical" and "field" momenta, and consider the interaction of the particle with external electromagnetic fields \mathbf{E}_{ext} and \mathbf{B}_{ext} . In the spirit of Poincaré, we do not preclude that the charge is associated with a nonelectromagnetic field that generates the stresses required for stability of the charge.⁷³ Then, conservation of momentum of this system can be expressed as,

$$\frac{d\mathbf{P}_{\text{mech,ext}}}{dt} + \frac{d\mathbf{P}_{\text{mech},e}}{dt} + \frac{d\mathbf{P}_{\text{EM}}}{dt} + \frac{d\mathbf{P}_{\text{other}}}{dt} = 0, \quad (55)$$

where $\mathbf{P}_{\text{other}}$ is associated only with the charge e . The electromagnetic fields \mathbf{E} and \mathbf{B} consist of the external fields, and the (self) fields of the charge,

$$\mathbf{E} = \mathbf{E}_{\text{ext}} + \mathbf{E}_e, \quad \mathbf{B} = \mathbf{B}_{\text{ext}} + \mathbf{B}_e, \quad (56)$$

such that the electromagnetic-field momentum can be written as,

$$\mathbf{P}_{\text{EM}} = \frac{c}{4\pi} \int \mathbf{E} \times \mathbf{B} d\text{Vol} = \mathbf{P}_{\text{EM,ext}} + \mathbf{P}_{\text{EM},e} + \mathbf{P}_{\text{EM,int}}, \quad (57)$$

where,

$$\mathbf{P}_{\text{EM,ext}} = \frac{c}{4\pi} \int \mathbf{E}_{\text{ext}} \times \mathbf{B}_{\text{ext}} d\text{Vol}, \quad \mathbf{P}_{\text{EM},e} = \frac{c}{4\pi} \int \mathbf{E}_e \times \mathbf{B}_e d\text{Vol}, \quad (58)$$

and the interaction electromagnetic-field momentum is,

$$\mathbf{P}_{\text{EM,int}} = \frac{c}{4\pi} \int \mathbf{E}_{\text{ext}} \times \mathbf{B}_e d\text{Vol} + \frac{c}{4\pi} \int \mathbf{E}_e \times \mathbf{B}_{\text{ext}} d\text{Vol}. \quad (59)$$

⁷³We ignore the possibility that the sources of the external field are associated with a nonelectromagnetic field as well.

Then, eq. (55) can be written as,

$$\frac{d\mathbf{P}_{\text{mech,ext}}}{dt} + \frac{d\mathbf{P}_{\text{mech},e}}{dt} = -\frac{d\mathbf{P}_{\text{EM,ext}}}{dt} - \frac{d\mathbf{P}_{\text{EM,int}}}{dt} - \frac{d\mathbf{P}_{\text{EM},e}}{dt} - \frac{d\mathbf{P}_{\text{other}}}{dt}. \quad (60)$$

If the sources of the external electromagnetic field are very far from the accelerated charge, the external field will not be affected by the charge (during some finite time interval of interest), then $-d\mathbf{P}_{\text{EM,ext}}/dt$ is equal to $d\mathbf{P}_{\text{mech,ext}}/dt$, and eq. (60) simplifies to,

$$\frac{d\mathbf{P}_{\text{mech},e}}{dt} = -\frac{d\mathbf{P}_{\text{EM,int}}}{dt} - \frac{d\mathbf{P}_{\text{EM},e}}{dt} - \frac{d\mathbf{P}_{\text{other}}}{dt}. \quad (61)$$

The impressive result of [197] is that, independent of whether the charge is finite or pointlike,

$$-\frac{d\mathbf{P}_{\text{EM},e}}{dt} = \mathbf{F}_{\text{damping}}, \quad (62)$$

where $\mathbf{F}_{\text{damping}}$ is the electromagnetic radiation-reaction force of our eq. (21), as first found by Abraham [72], and later found by Dirac [111]. This leads us to infer that,

$$-\frac{d\mathbf{P}_{\text{EM},e}}{dt} = \mathbf{F}_{\text{S,EM}}. \quad (63)$$

For the case of a uniform, static, external electric field (with zero external magnetic field), both the damping force (21) and the interaction electromagnetic-field momentum (59) vanish, the acceleration is constant in the instantaneous rest frame of the charge,⁷⁴ and eq. (61) reduces to,

$$\frac{d\mathbf{P}_{\text{mech},e}}{dt} = -\frac{d\mathbf{P}_{\text{other}}}{dt} \quad (\text{constant acceleration}). \quad (64)$$

This suggests that in general the Poincaré stresses should not be ignored in discussions of the classical equation of motion of a charged particle.

We can also relate the rate of change of mechanical momentum of the charge e , with electric charge density ρ_e , to the sum of the forces on it, which consist of the Lorentz forces,

$$\mathbf{F}_{\text{ext}} = \int \rho_e \left(\mathbf{E}_{\text{ext}} + \frac{\mathbf{v}}{c} \times \mathbf{B}_{\text{ext}} \right) d\text{Vol}, \quad \mathbf{F}_{\text{S,EM}} = \int \rho_e \left(\mathbf{E}_e + \frac{\mathbf{v}}{c} \times \mathbf{B}_e \right) d\text{Vol}, \quad (65)$$

due to the external and self electromagnetic fields, as well as the possible self force $\mathbf{F}_{\text{S,other}}$ associated with the nonelectromagnetic field. That is,

$$\frac{d\mathbf{P}_{\text{mech},e}}{dt} = \mathbf{F}_{\text{ext}} + \mathbf{F}_{\text{S,EM}} + \mathbf{F}_{\text{S,other}}. \quad (66)$$

If we accept the relation (63), then eqs. (61) and (65) together imply that

$$\mathbf{F}_{\text{ext}} + \mathbf{F}_{\text{S,other}} = -\frac{d\mathbf{P}_{\text{EM,int}}}{dt} - \frac{d\mathbf{P}_{\text{other}}}{dt}. \quad (67)$$

For the case of uniform acceleration, where the electromagnetic self force and the electromagnetic interaction momentum both vanish, we arrive at the peculiar relation,

$$\frac{d\mathbf{P}_{\text{mech},e}}{dt} = \mathbf{F}_{\text{ext}} + \mathbf{F}_{\text{S,other}} = -\frac{d\mathbf{P}_{\text{other}}}{dt} \quad (\text{constant acceleration}). \quad (68)$$

⁷⁴See, for example, sec. 2.1 of [187]. The interaction field momentum vanishes due to the high symmetry of this case.

Appendix C: Limits on the Applicability of Classical Electromagnetic Fields as Inferred from the Radiation Reaction

Neither Eliezer nor Landau, sec. 25 above, (nor most subsequent authors) seem to have considered what is meant by the self force/radiation reaction not being too strong. So, we transcribe here some discussion by the author on this theme, given in [1].

It suffices to consider only the low-velocity limit (as used by Lorentz [39] and Planck [47]), in which the equation of motion is simply,

$$m\dot{\mathbf{v}} \approx \gamma\dot{m}\mathbf{v} = \mathbf{F}_{\text{ext}} + \mathbf{F}_{\text{self}} \approx e\mathbf{E} + e\frac{\mathbf{v}}{c} \times \mathbf{B} + \frac{2e^2}{3c^3}\ddot{\mathbf{v}}, \quad (69)$$

where \mathbf{E} and \mathbf{B} are the external electromagnetic fields. From this we learn that in the first approximation, the acceleration of the charge is just $\dot{\mathbf{v}} \approx e\mathbf{E}/m$. Further, if the second time derivative of the velocity is small we estimate it by taking the derivative of (69),

$$\ddot{\mathbf{v}} \approx \frac{e\dot{\mathbf{E}}}{m} + \frac{e}{m} \frac{\dot{\mathbf{v}}}{c} \times \mathbf{B} + \frac{e}{m} \frac{\mathbf{v}}{c} \times \dot{\mathbf{B}} \approx \frac{e\dot{\mathbf{E}}}{m} + \frac{e^2}{mc^2}\mathbf{E} \times \mathbf{B}, \quad (70)$$

where we have ignore the term proportional to \mathbf{v}/c . Thus, in these approximations, the self force is given by,

$$\mathbf{F}_{\text{self}} \approx \frac{2e^2}{3c^3} \left(\frac{e\dot{\mathbf{E}}}{m} + \frac{e^2}{m^2c}\mathbf{E} \times \mathbf{B} \right). \quad (71)$$

The first term in (71) contributes only for time-varying fields, which we now take to have frequency ω and reduced wavelength λ ; hence, $\dot{\mathbf{E}} \propto \omega\mathbf{E}$. The second term contributes only when $\mathbf{E} \times \mathbf{B} \neq 0$, which is most likely to be in a wave (with $E = B$) if the fields are large. So, for a charge in an external wave field, the magnitude of the self force is,

$$F_{\text{resist}} \approx \frac{2}{3}eE \sqrt{\left(\frac{e^2}{mc^2} \frac{\omega}{c}\right)^2 + \left(\frac{e^3E}{m^2c^4}\right)^2} \approx F_{\text{ext}} \sqrt{\left(\frac{r_0}{\lambda}\right)^2 + \left(\frac{E}{e/r_0^2}\right)^2}, \quad (72)$$

where $r_0 = e^2/mc^2 = 2.8 \times 10^{-13}$ cm is the classical electron radius.

Following the spirit of Lorentz comment in 1906 [81], the premise of this discussion is that the notion of the self force makes physical sense only when it is small compared to the external force. Here we don't explore whether the length r_0 describes a physical electron; we simply consider it to be a length that arises from the charge and mass of an electron.⁷⁵ Rather, we concentrate on the implication of eq. (72) for the electromagnetic field. Then, we infer that a classical description becomes implausible for fields whose wavelength is small compared to length r_0 , or whose strength is large compared to e/r_0^2 .

Already in 1900, Planck [55] had introduced to quantum of action, \hbar .

⁷⁵This theme is pursued in sec. 10.2 of [151].

In this context, it is suggestive to multiply and divide eq. (72) by Planck's constant \hbar ,

$$F_{\text{self}} \approx F_{\text{ext}} \sqrt{\left(\frac{e^2 \hbar \omega}{\hbar c m c}\right)^2 + \left(\frac{e^2 e \hbar}{\hbar c m^2 c^3} E\right)^2} = \alpha F_{\text{ext}} \sqrt{\left(\frac{\lambda_C}{\lambda}\right)^2 + \left(\frac{E}{E_{\text{crit}}}\right)^2}, \quad (73)$$

where $\alpha = e^2/\hbar c$ is the QED fine structure constant, $\lambda_C = \hbar/mc$ is the (reduced) Compton wavelength of an electron and,

$$E_{\text{crit}} = \frac{m^2 c^3}{e \hbar} = 1.6 \times 10^{16} \text{ V/cm} = 3.3 \times 10^{13} \text{ gauss}, \quad (74)$$

is the QED critical field strength. The quantity E_{crit} was introduced by Sauter in 1931 [108] when he resolved Klein's paradox [107] by arguing that for $E > E_{\text{crit}}$ the electric field spontaneously breaks down into e^+e^- pairs, so it should not be surprising that the reflection coefficient of a charge energy such a strong-field region could exceed unity.⁷⁶

Thus, our naïve quantum theory (classical electromagnetism plus \hbar) leads us to expect important departures from classical electromagnetism for waves of wavelength much shorter than the Compton wavelength of the electron, and for fields of strength larger than the QED critical field strength.⁷⁷

While this argument (without the interpretation of the QED critical field strength) could have been given in 1906, it has never appeared in the literature.

References

- [1] K.T. McDonald, *Limits on the Applicability of Classical Electromagnetic Fields as Inferred from the Radiation Reaction* (May 12, 1997), <http://kirkmcd.princeton.edu/examples/radreact.pdf>
- [2] J. Kepler, *De Cometis* (1619), http://kirkmcd.princeton.edu/examples/astro/kepler_de_cometis.pdf
- [3] I. Newton, *Philosophiæ Naturalis Principia Mathematica* (1686), http://kirkmcd.princeton.edu/examples/mechanics/newton_principia.pdf
- [4] M. Faraday, *Experimental Researches in Electricity*, Phil. Trans. Roy. Soc. London **122**, 125 (1832), http://kirkmcd.princeton.edu/examples/EM/faraday_ptrs1_122_163_32.pdf
- [5] G.G. Stokes, *On some Cases of Fluid Motion*, Trans. Camb. Phil. Soc. **8**, 105 (1843), http://kirkmcd.princeton.edu/examples/fluids/stokes_tcps_8_105_43.pdf
- [6] W. Weber, *Electrodynamische Massbestimmungen über ein allgemeines Grundgesetz der elektrischen Wirkung*, Abh. König. Sächs. Gesell. Wiss., 209 (1846), http://kirkmcd.princeton.edu/examples/EM/weber_aksgw_209_46.pdf
http://kirkmcd.princeton.edu/examples/EM/weber_aksgw_209_46_english.pdf

⁷⁶For additional remarks on the QED critical field strength, see sec. 3.2 of [1].

⁷⁷If we were to accept that the Schott term in the self force should be “renormalized” away, the second term in eq. (71) would remain, still leading to the notion of a critical field strength.

- [7] W. Thomson, *Note on the Possible Density of the Luminiferous Medium and on the Mechanical Value of a Cubic Mile of Sunlight*, Phil. Mag. **9**, 36 (1855),
http://kirkmcd.princeton.edu/examples/EM/thomson_pm_9_36_55.pdf
- [8] G. Kirchhoff, *Ueber das Verhältniß zwischen dem Emissionsvermögen und dem Absorptionsvermögen der Körper für Wärme und Licht*, Ann. d. Phys. **109**, 275 (1860),
http://kirkmcd.princeton.edu/examples/optics/kirchhoff_ap_109_275_60.pdf
On the Relation between the Radiating and Absorbing Powers of different Bodies for Light and Heat, Phil. Mag. **20**, 1 (1860),
http://kirkmcd.princeton.edu/examples/statmech/kirchhoff_pm_20_1_60.pdf
- [9] J. Plücker, *On the Action of the Magnet upon the Electrical Discharge in Rarefied Gases*, Phil. Mag. **16**, 119 (1858),
http://kirkmcd.princeton.edu/examples/EP/plucker_pm_16_119_58.pdf
- [10] J. Plücker, *Abstract of a series of Papers and Notes concerning the Electric Discharge through Rarefied Gases and Vapours*, Proc. Roy. Soc. London **10**, 256 (1860),
http://kirkmcd.princeton.edu/examples/EM/plucker_prsl_10_256_60.pdf
- [11] J.C. Maxwell, *On Physical Lines of Force. Part III.—The Theory of Molecular Vortices applied to Statical Electricity*, Phil. Mag. **23**, 12 (1862),
http://kirkmcd.princeton.edu/examples/EM/maxwell_pm_23_12_62.pdf
- [12] B. Stewart, *An Elementary Treatise on Heat* (Clarendon Press, 1866),
http://kirkmcd.princeton.edu/examples/statmech/stewart_heat_66.pdf
- [13] B. Riemann, *Ein Beitrag zur Elektrodynamik*, Ann. d. Phys. **207**, 237 (1867),
http://kirkmcd.princeton.edu/examples/EM/riemann_ap_207_237_67.pdf
A Contribution to Electrodynamics, Phil. Mag. **34**, 368 (1867),
http://kirkmcd.princeton.edu/examples/EM/riemann_pm_34_368_67.pdf
- [14] L. Lorenz, *Ueber die Identität der Schwingungen des Lichts mit den elektrischen Strömen*, Ann. d. Phys. **207**, 243 (1867),
http://kirkmcd.princeton.edu/examples/EM/lorenz_ap_207_243_67.pdf
On the Identity of the Vibration of Light with Electrical Currents, Phil. Mag. **34**, 287 (1867), http://kirkmcd.princeton.edu/examples/EM/lorenz_pm_34_287_67.pdf
- [15] J.W. Strutt, *On the Light from the Sky, its Polarization and Colour*, Phil. Mag. **41**, 107, 274 (1871), http://kirkmcd.princeton.edu/examples/EM/rayleigh_pm_41_107_71.pdf
- [16] J.W. Strutt, *On the Scattering of Light by small Particles*, Phil. Mag. **41**, 447 (1871),
http://kirkmcd.princeton.edu/examples/EM/rayleigh_pm_41_447_71.pdf
- [17] B. Stewart, *Temperature Equilibrium of an Enclosure in which there is a Body in Visible Motion*, Brit. Assoc. Reports, 41st Meeting, Notes and Abstracts, p. 45 (1871),
http://kirkmcd.princeton.edu/examples/EM/stewart_bar_41_45_71.pdf
This meeting featured an inspirational address by W. Thomson as a memorial to Herschel; among many other topics Thomson speculates on the size of atoms, on the

origin of life on Earth as due to primitive organisms arriving in meteorites, and on how the Sun's source of energy cannot be an influx of matter as might, however, explain the small advance of the perihelion of Mercury measured by LeVerrier.

- [18] J.C. Maxwell, *A Treatise on Electricity and Magnetism* (Clarendon Press, 1873; 3rd ed. 1904), Art. 62, http://kirkmcd.princeton.edu/examples/EM/maxwell_treatise_v1_04.pdf
- [19] J.C. Maxwell, *A Treatise on Electricity and Magnetism*, Vol. 2 (Clarendon Press, 1873), http://kirkmcd.princeton.edu/examples/EM/maxwell_treatise_v2_73.pdf
Vol. 2, 3rd ed. (Clarendon Press, 1892),
http://kirkmcd.princeton.edu/examples/EM/maxwell_treatise_v2_92.pdf
- [20] B. Stewart, *On Æthereal Friction*, Brit. Assoc. Reports, 43rd Meeting, Notes and Abstracts, pp. 32-35 (1873),
http://kirkmcd.princeton.edu/examples/EM/stewart_bar_43_32_73.pdf
Stewart argued that the radiation resistance felt by a charge moving through blackbody radiation should vanish as the temperature of the bath went to zero, just as he expected the electrical resistance of a conductor to vanish at zero temperature. [The 43rd meeting was also the occasion of a report by Maxwell on the exponential atmosphere as an example of statistical mechanics (pp. 29-32), by Rayleigh on the diffraction limit to the sharpness of spectral lines (p. 39), and perhaps of greatest significance to the attendees, a note by A.H. Allen on the detection of adulteration of tea (p. 62).]
- [21] W. Crookes, *The Mechanical Action of Light*, Pop. Sci. Mon. **7**, 739 (1875),
http://kirkmcd.princeton.edu/examples/EP/crookes_psm_7_683_75.pdf
- [22] W. Crookes, *On Repulsion resulting from Radiation*, Phil. Trans. Roy. Soc. London **166**, 325 (1876), http://kirkmcd.princeton.edu/examples/optics/crookes_ptrsl_166_325_76.pdf
- [23] A. Schuster, *On the Nature of the Force producing the Motion of a Body exposed to Rays of Heat and Light*, Phil. Trans. Roy. Soc. London **166**, 715 (1876),
http://kirkmcd.princeton.edu/examples/EM/schuster_ptrsl_166_715_76.pdf
- [24] W. Crookes, *On Radiant Matter*, Pop. Sci. Mon. **16**, 13, 157 (1879),
http://kirkmcd.princeton.edu/examples/EP/crookes_psm_16_13_157_79.pdf
- [25] J.J. Thomson, *Electric and Magnetic Effects Produced by Motion of Electrified Bodies*, Phil. Mag. **11**, 229 (1881), http://kirkmcd.princeton.edu/examples/EM/thomson_pm_11_229_81.pdf
- [26] Lord Rayleigh, *On the Electromagnetic Theory of Light*, Phil. Mag. **12**, 81 (1881),
http://kirkmcd.princeton.edu/examples/EM/rayleigh_pm_12_81_81.pdf
- [27] G.F. FitzGerald, *On the Quantity of Energy Transferred to the Ether by a Variable Current*, Trans. Roy. Dublin Soc. **3** (1883),
http://kirkmcd.princeton.edu/examples/EM/fitzgerald_trds_83.pdf
On the Energy Lost by Radiation from Alternating Electric Currents, Brit. Assoc. Rep. **175**, 343 (1883), http://kirkmcd.princeton.edu/examples/EM/fitzgerald_bar_83.pdf

- [28] J.H. Poynting, *On the Transfer of Energy in the Electromagnetic Field*, Phil. Trans. Roy. Soc. London **175**, 343 (1884),
http://kirkmcd.princeton.edu/examples/EM/poynting_pt_175_343_84.pdf
- [29] H. Hertz, *Ueber sehr schnelle elektrische Schwingungen*, Ann. d. Phys. **31**, 421 (1887),
http://kirkmcd.princeton.edu/examples/EM/hertz_ap_31_421_87.pdf
- [30] H. Hertz, *Ueber elektrodynamische Wellen im Luftraume und deren Reflexion*, Ann. d. Phys. **34**, 609 (1889), http://kirkmcd.princeton.edu/examples/EM/hertz_apc_34_609_88.pdf
- [31] H. Hertz, *Electric Waves* (Macmillan, 1900),
http://kirkmcd.princeton.edu/examples/EM/hertz_electric_oscillations.pdf
- [32] O. Heaviside, *On the Electromagnetic Effects due to the Motion of Electrification through a Dielectric*, Phil. Mag. **27**, 324 (1889),
http://kirkmcd.princeton.edu/examples/EM/heaviside_pm_27_324_89.pdf
- [33] G.F. Fitzgerald, *The Ether and the Earth's Atmosphere*, Science **13**, 390 (1889),
http://kirkmcd.princeton.edu/examples/EM/fitzgerald_science_13_390_89.pdf
- [34] H. Hertz, *Die Kräfte elektrischer Schwingungen, behandelt nach der Maxwell'schen Theorie*, Ann. d. Phys. **36**, 1 (1889),
http://kirkmcd.princeton.edu/examples/EM/hertz_ap_36_1_89.pdf
- [35] H. Hertz, *The Forces of Electrical Oscillations Treated According to Maxwell's Theory*, Nature **39**, 402, 450, 547 (1889),
http://kirkmcd.princeton.edu/examples/EM/hertz_nature_39_402_89.pdf
- [36] O.J. Lodge and J.L. Howard, *On Electric Radiation and its Concentration by Lenses*, Proc. Phys. Soc. London **10**, 143 (1889),
http://kirkmcd.princeton.edu/examples/EM/lodge_ppsl_10_143_89.pdf
 Also published as Phil. Mag. **28**, 48 (1889),
http://kirkmcd.princeton.edu/examples/EM/lodge_pm_28_48_89.pdf
- [37] V. Bjerknes, *Ueber die Dämpfung schneller elektrischen Schwingungen*, Ann. d. Phys. **44**, 75 (1891), http://kirkmcd.princeton.edu/examples/EM/bjerknes_ap_44_74_91.pdf
- [38] H. Poincaré, *Sur la théorie des oscillations hertiennes*, Compte Rendus Acad. Sci. **113**, 515 (1891), http://kirkmcd.princeton.edu/examples/EM/poincare_cras_113_515_91.pdf
- [39] H.A. Lorentz, *La Théorie Électromagnétique de Maxwell et son Application aux Corps Mouvants*, Arch. Néerl. **25**, 363 (1892),
http://kirkmcd.princeton.edu/examples/EM/lorentz_theorie_electromagnetique_92.pdf
- [40] H.A. Lorentz, *De relatieve beweging van de aarde en den aether*, Zit. Akad. Wet. Amsterdam **1**, 74 (1892), http://kirkmcd.princeton.edu/examples/EM/lorentz_zawa_1_74_92.pdf
The Relative Motion of the Earth and the Aether,
http://kirkmcd.princeton.edu/examples/EM/lorentz_zawa_1_74_92_english.pdf

- [41] J.J. Thomson, *Recent Researches in Electricity and Magnetism* (Clarendon Press, 1893), p. 9, http://kirkmcd.princeton.edu/examples/EM/thomson_recent_researches_in_electricity.pdf
- [42] H. Poincaré, *Les Oscillations Électriques* (Paris, 1894), http://kirkmcd.princeton.edu/examples/EM/poincare_osc_elec_94.pdf
- [43] G.J. Stoney, *Of the "Electron," or Atom of Electricity*, Phil. Mag. **38**, 418, 157 (1894), http://kirkmcd.princeton.edu/examples/EM/stoney_pm_38_418_94.pdf
- [44] H.A. Lorentz, *Versuch einer Theorie der electrischen und optischen Erscheinungen in bewegten Körpern* (Brill, Leiden, 1895), http://kirkmcd.princeton.edu/examples/EM/lorentz_versuch_95.pdf
Attempt of a Theory of Electrical and Optical Phenomena in Moving Bodies, http://kirkmcd.princeton.edu/examples/EM/lorentz_versuch_95_english.pdf
- [45] M. Planck, *Absorption und Emission electrischer Wellen durch Resonanz*, Ann. d. Phys. **57**, 1 (1896), http://kirkmcd.princeton.edu/examples/EM/planck_ap_57_1_96.pdf
- [46] J. Larmor, *On the Theory of the Magnetic Influence on Spectra; and on the Radiation from moving Ions*, Phil. Mag. **44**, 503 (1897), http://kirkmcd.princeton.edu/examples/EM/larmor_pm_44_503_97.pdf
- [47] M. Planck, *Über electrische Schwingungen, welche durch Resonanz erregt und durch Strahlung gedämpft werden*, Sitz. K. P. Akad. Wiss. Berlin, 151 (1896), http://kirkmcd.princeton.edu/examples/EM/planck_skpaw_151_96.pdf
Ann. d. Phys. **60**, 577 (1897), http://kirkmcd.princeton.edu/examples/EM/planck_ap_60_577_97.pdf
- [48] J.J. Thomson, *Cathode Rays*, Phil. Mag. **44**, 293 (1897), http://kirkmcd.princeton.edu/examples/EP/thomson_pm_44_293_97.pdf
- [49] M. Abraham, *Die electrischen Schwingungen um einem stabförmigen Leiter, behandelt nach der Maxwell'schen Theorie*, Ann. d. Phys. **66**, 435 (1898), http://kirkmcd.princeton.edu/examples/EM/abraham_ap_66_435_98.pdf
- [50] A. Liénard, *Champ électrique et magnétique produit par une charge électrique contentée en un point et animée d'un mouvement quelconque*, L'Éclairage Élect. **16**, 5, 53, 106 (1898), http://kirkmcd.princeton.edu/examples/EM/lienard_ee_16_5_98.pdf
- [51] M. Planck, *Über irreversible Strahlungsvorgänge*, Sitz. König. Preuss. Akad. Wissen. **26**, 440 (1899), http://kirkmcd.princeton.edu/examples/statmech/planck_skpaw_26_440_99.pdf
- [52] E. Rutherford, *Uranium Radiation and the Electrical Conduction produced by it*, Phil. Mag. **47**, 109 (1899), http://kirkmcd.princeton.edu/examples/EP/rutherford_pm_47_109_99.pdf
- [53] Lord Rayleigh, *On the Transmission of Light through an Atmosphere containing Small Particles in Suspension, and on the Origin of the Blue of the Sky*, Phil. Mag. **47**, 375 (1899), http://kirkmcd.princeton.edu/examples/EM/rayleigh_pm_47_375_99.pdf

- [54] *Recueil de Travaux offerts par les Auteurs à H.A. Lorentz*, Arch. Néerl. **5** (1900), http://kirkmcd.princeton.edu/examples/EM/lorentz_symposium_00.pdf
- [55] M. Planck, *Zur Theorie des Gesetzes der Energieverteilung im Normalspektrum*, Verh. Deutsch. Phys. Ges. **2**, 237 (1900), http://kirkmcd.princeton.edu/examples/statmech/planck_vdpg_2_237_00.pdf
- [56] H. Poincaré, *Théorie de Lorentz et le Principe de la Réaction*, Arch. Néerl. **5**, 252 (1900), http://kirkmcd.princeton.edu/examples/EM/poincare_an_5_252_00.pdf
- [57] E. Wiechert, *Elektrodynamische Elementargesetze*, Arch. Néerl. **5**, 549 (1900); Ann. d. Phys. **309**, 667 (1901), http://kirkmcd.princeton.edu/examples/EM/wiechert_ap_309_667_01.pdf
- [58] W. Wien, *Über die Möglichkeit einer elektromagnetischen Begründung der Mechanik*, Arch. Neer. **2**, 96 (1900), http://kirkmcd.princeton.edu/examples/EM/wien_ansen_2_96_00.pdf
- [59] M. Abraham, *Funkentelegraphie und Elektrodynamik*, Phys. Z. **2**, 329 (1901), http://kirkmcd.princeton.edu/examples/EM/abraham_pz_2_329_01.pdf
- [60] H. Brooks, *Damping of the Oscillations in the Discharge of a Leyden-jar*, Phil. Mag. **2**, 92 (1901), http://kirkmcd.princeton.edu/examples/EM/brooks_pm_2_92_01.pdf
- [61] P. Lebedew, *Untersuchen über die Druckkräfte des Lichtes*, Ann. d. Phys. **6**, 433 (1901), http://kirkmcd.princeton.edu/examples/EM/lebedev_ap_6_433_01.pdf
- [62] E.F. Nichols and G.F. Hull, *A Preliminary Communication on the Pressure of Heat and Light Radiation*, Phys. Rev. **13**, 307 (1901), http://kirkmcd.princeton.edu/examples/EM/nichols_pr_13_307_01.pdf
- [63] M. Abraham, *Dynamik des Electrons*, Gött. Nachr., 20 (1902), http://kirkmcd.princeton.edu/examples/EM/abraham_ngwg_20_02.pdf
- [64] O. Heaviside, *The Waste of Energy from a Moving Electron*, Nature **67**, 6 (1902), http://kirkmcd.princeton.edu/examples/EM/heaviside_nature_67_6_02.pdf
- [65] W. Kaufmann, *Die elektromagnetische Masse des Elektrons*, Phys. Z. **4**, 54 (1902), http://kirkmcd.princeton.edu/examples/EM/kaufmann_pz_4_54_02.pdf
The Electromagnetic Mass of the Electron, http://kirkmcd.princeton.edu/examples/EM/kaufmann_pz_4_54_02_english.pdf
- [66] M. Abraham, *Prinzipien der Dynamik des Elektrons*, Ann. d. Phys. **10**, 105 (1903), http://physics.princeton.edu/~mcdonald/examples/EM/abraham_ap_10_105_03.pdf
http://kirkmcd.princeton.edu/examples/EM/abraham_ap_10_105_03_english.pdf
- [67] E.E. Nichols and G.F. Hull, *The Pressure due to Radiation*, Ap. J. **17**, 315 (1903), http://kirkmcd.princeton.edu/examples/EM/nichols_apj_17_315_03.pdf
- [68] H.A. Lorentz, *Weiterbildung der Maxwellschen Theorie. Elektronentheorie*, Enzykl. Math. Wiss. **5**, part II, 145 (1904), especially secs. 20-21, http://kirkmcd.princeton.edu/examples/EM/lorentz_emw_5_2_145_04.pdf

- [69] J.J. Thomson, *The Magnetic Properties of Systems of Corpuscles describing Circular Orbits*, Phil. Mag. **6**, 673 (1903),
http://kirkmcd.princeton.edu/examples/EM/thomson_pm_6_673_03.pdf
- [70] M. Abraham, *Zur Theorie der Strahlung und des Strahlungsdruckes*, Ann. d. Phys. **14**, 236 (1904), http://kirkmcd.princeton.edu/examples/EM/abraham_ap_14_236_04.pdf
- [71] M. Abraham, *The Reaction of the Radiation on a Moving Electron*, Brit. Assoc. Rep. p. 436 (1904), http://kirkmcd.princeton.edu/examples/EM/abraham_bar_436_04.pdf
- [72] M. Abraham, *Theorie der Elektrizität. Zweiter Band: Elektromagnetische Theorie der Strahlung* (Teubner, Leipzig, 1905),
http://kirkmcd.princeton.edu/examples/EM/abraham_theorie_der_strahlung_v2_05.pdf
- [73] A. Sommerfeld, *Zur Elektronen Theorie. II. Grundlagen für eine allgemeine dynamik des Elektrons*, Nachr. Gött. Wiss. Gesell., 363 (1904),
http://kirkmcd.princeton.edu/examples/EM/sommerfeld_ngwg_363_04.pdf
- [74] A. Sommerfeld, *Simplified deriviations of the Field and the Forces of an Electron, moving in any given way*, K. Nederl. Akad. Wiss. **7**, 346 (1905),
http://kirkmcd.princeton.edu/examples/EM/sommerfeld_knaw_7_346_05.pdf
- [75] J.J. Thomson, *On the Structure of the Atom: an Investigation of the Stability and Periods of Oscillation of a number of Corpuscles arranged at equal intervals around the Circumference of a Circle; with Application of the results to the Theory of Atomic Structure*, Phil. Mag. **7**, 237 (1904),
http://kirkmcd.princeton.edu/examples/EM/thomson_pm_7_237_04.pdf
- [76] H.A. Lorentz, *Ergebnisse und Probleme der Elektronentheorie* (Springer, Berlin, Leipzig, 1905), http://kirkmcd.princeton.edu/examples/EM/lorentz_elektronentheorie_05.pdf
- [77] A. Einstein, *Zur Elektrodynamik bewegten Körper*, Ann. d. Phys. **17**, 891 (1905),
http://kirkmcd.princeton.edu/examples/EM/einstein_ap_17_891_05.pdf
http://kirkmcd.princeton.edu/examples/EM/einstein_ap_17_891_05_english.pdf
- [78] A. Einstein, *Ist die Trägheit eines Körpers von seinem Energieinhalt abhängig?* Ann. d. Phys. **18**, 639 (1905),
http://kirkmcd.princeton.edu/examples/EM/einstein_ap_18_639_05.pdf
 Translation: *Does the Inertia of a Body Depend upon its Energy-Content?*,
http://kirkmcd.princeton.edu/examples/EM/einstein_ap_18_639_05_english.pdf
- [79] H. Poincaré, *Sur la Dynamique de l'Électron*, Compte Rendus **140**, 1504 (1905),
http://kirkmcd.princeton.edu/examples/EM/poincare_cras_140_1504_05.pdf
http://kirkmcd.princeton.edu/examples/EM/poincare_cras_140_1504_05_english.pdf
- [80] H. Poincaré, *Sur la Dynamique de l'Électron*, Rendiconti del Circolo Matematico di Palermo **21**, 129 (1906), http://kirkmcd.princeton.edu/examples/EM/poincare_rcmp_21_129_06.pdf
 for a translation, see H.M. Schwartz, *Poincaré's Rendiconti Paper on Relativity, Parts*

- I-III, Am. J. Phys **39**, 1287 (1971); **40**, 862, 1282 (1972),
http://kirkmcd.princeton.edu/examples/EM/poincare_ajp_39_1287_71.pdf http://kirkmcd.princeton.edu/examples/EM/poincare_ajp_40_862_72.pdf
http://kirkmcd.princeton.edu/examples/EM/poincare_ajp_40_1282_72.pdf
- [81] H.A. Lorentz, *The Theory of Electrons* (Teubner, 1909), secs. 26 and 37 and note 18,
http://kirkmcd.princeton.edu/examples/EM/lorentz_theory_of_electrons_09.pdf
- [82] J.J. Thomson, *Conduction of Electricity Through Gases*, 2nd ed. (Cambridge U. Press, 1906),
http://kirkmcd.princeton.edu/examples/EM/thomson_conduction_of_electricity_through_gases.pdf
- [83] M. Planck, *Vorlesungen über die Theorie der Wärmestrahlung* (J. Barth, Leipzig, 1906), sec. III,
http://kirkmcd.princeton.edu/examples/statmech/planck_theorie_warme_06.pdf
 Details on radiation damping were omitted from the second edition, which has been translated as *The Theory of Heat Radiation*, (Blakiston, Philadelphia, 1914),
http://kirkmcd.princeton.edu/examples/statmech/planck_heat_radiation.pdf
- [84] A.W. Conway, *The Dynamics of a Rigid Electron*, Proc. Roy. Irish Acad. **27**, 169 (1908),
http://kirkmcd.princeton.edu/examples/EM/conway_pria_27_169_08.pdf
- [85] R. Rüdénberg, *Der Empfang elektrischer Wellen in der drahtlosen Telegraphie*, Ann. d. Phys. **25**, 446 (1908),
http://kirkmcd.princeton.edu/examples/EM/rudenberg_ap_25_446_08.pdf
- [86] M. Abraham, *Theorie der Elektrizität. Zweiter Band: Elektromagnetische Theorie der Strahlung*, 2nd ed. (Teubner, 1908),
http://kirkmcd.princeton.edu/examples/EM/abraham_foppl_elektrizitat_v2_08.pdf
- [87] J. Hadamard, *Theorie des Équations aux Dérivées Partielles Linéaires Hyperboliques et du Probleme de Cauchy*, Acta Math. **31**, 333 (1908),
http://kirkmcd.princeton.edu/examples/mechanics/hadamard_am_31_333_08.pdf
- [88] H. Minkowski, *Raum und Zeit*, Jahresb. Deutschen Math.-Verein. 1 (1909),
http://kirkmcd.princeton.edu/examples/EM/minkowski_jdmv_1_09.pdf
http://kirkmcd.princeton.edu/examples/EM/minkowski_jdmv_1_09_english.pdf
 pp. 49-50 of http://kirkmcd.princeton.edu/examples/GR/minkowski_papers.pdf
- [89] M. von Laue, *Die Wellenstrahlung einer bewegten Punktladung nach dem Relativitätsprinzip*, Verh. Deutsch. Phys. Gesell. **10**, 838 (1908),
http://kirkmcd.princeton.edu/examples/EM/vonlaue_vdpg_10_838_08.pdf
http://kirkmcd.princeton.edu/examples/EM/vonlaue_vdpg_13_513_11_english.pdf
 Ann. d. Phys. **28**, 436 (1909),
http://physics.princeton.edu/~mcdonald/examples/EM/vonlaue_ap_28_436_09.pdf
- [90] M. Born, *Die Theorie des starren Elektrons in der Kinematik des Relativitätsprinzips*, Ann. d. Phys. **30**, 1 (1909),
http://kirkmcd.princeton.edu/examples/EM/born_ap_30_1_09.pdf
http://kirkmcd.princeton.edu/examples/EM/born_ap_30_1_09_english.pdf

- [91] A. Sommerfeld, *Zur Relativitätstheorie. II. Vierdimensionale Vektoranalysis*, Ann. d. Phys. **33**, 649 (1910),
http://kirkmcd.princeton.edu/examples/GR/sommerfeld_ap_33_649_10.pdf
http://kirkmcd.princeton.edu/examples/GR/sommerfeld_ap_33_649_10_english.pdf
- [92] M. von Laue, *Das Relativitätsprinzip* (Vieweg, Braunschweig, 1911),
http://kirkmcd.princeton.edu/examples/GR/vonlaue_relativitat_11.pdf
- [93] J. Larmor, *On the Dynamics of Radiation*, Proc. 5th Intl. Cong. Math. (Cambridge) p. 197 (1912), http://kirkmcd.princeton.edu/examples/EM/larmor_pimc_197_12.pdf
- [94] G.A. Schott, *Electromagnetic Radiation and the Mechanical Reactions Arising from It* (Cambridge U. Press, 1912), especially Chap. XI and Appendix D.
http://kirkmcd.princeton.edu/examples/EM/schott_radiation_12.pdf
- [95] A. Sommerfeld, *Die Greensche Funktion der Schwingungsgleichung*, Jahresb. Deutsch. Math.-Verein. **21**, 309 (1912),
http://kirkmcd.princeton.edu/examples/EM/sommerfeld_jdmv_21_309_12.pdf
Partial Differential Equations in Physics (Academic Press, New York, 1949), sec. 28.
- [96] G.A. Schott, *On the Motion of the Lorentz Electron*, Phil. Mag. **29**, 49 (1915),
http://kirkmcd.princeton.edu/examples/EM/schott_pm_29_49_15.pdf
- [97] H.A. Lorentz, *The Connection between Momentum and Flow of Energy. Remarks Concerning the Structure of Electrons and Atoms*, Versl. K. Akad. Wet. Amsterdam **26**, 981 (1917), secs. 8-10,
http://kirkmcd.princeton.edu/examples/EM/lorentz_vkaw_26_981_17_english.pdf
- [98] P. Ehrenfest, *In that way does it become manifest in the fundamental laws of physics that space has three dimensions?* Proc. Kön. Neder. Akad. Wet. **20**, 200 (1918),
http://kirkmcd.princeton.edu/examples/GR/ehrenfest_pknaw_20_200_18.pdf
- [99] L. Page, *Is a Moving Mass Retarded by the Reaction of its own Radiation*. Phys. Rev. **11**, 376 (1918), http://kirkmcd.princeton.edu/examples/EM/page_pr_11_376_18.pdf
- [100] L. Page, *Is a Moving Star Retarded by its own Radiation?* Proc. Nat. Acad. Sci. **4**, 47 (1918), http://kirkmcd.princeton.edu/examples/EM/page_pnas_4_47_18.pdf
- [101] L. Page, *The Motion of an Electric Doublet*, Phys. Rev. **12**, 371 (1918),
http://kirkmcd.princeton.edu/examples/EM/page_pr_12_371_18.pdf
- [102] P. Ehrenfest, *Welche Rolle spielt die Dreidimensionalität des Raumes in den Grundgesetzen der Physik?* Ann. d. Phys. **61**, 440 (1920),
http://kirkmcd.princeton.edu/examples/GR/ehrenfest_ap_61_440_20.pdf
- [103] W. Pauli, *Relativitätstheorie*, Enzyl. Math. Wiss. Vol. V, part II, no. 19, 543 (1921),
http://kirkmcd.princeton.edu/examples/GR/pauli_emp_5_2_539_21.pdf
 translated as *Theory of Relativity* (Pergamon Press, 1958),
http://kirkmcd.princeton.edu/examples/GR/pauli_sec32.pdf

- [104] S.R. Milner, *Does an Accelerated Electron necessarily Radiate Energy on the Classical Theory?* Phil. Mag. **41**, 405 (1921),
http://kirkmcd.princeton.edu/examples/EM/milner_pm_41_405_21.pdf
 Phil. Mag. **44**, 1052 (1922),
http://kirkmcd.princeton.edu/examples/EM/milner_pm_44_1052_22.pdf
- [105] A.H. Compton, *A Quantum Theory of the Scattering of X-Rays by Light Elements*, Phys. Rev. **21**, 483 (1923), http://kirkmcd.princeton.edu/examples/QED/compton_pr_21_483_23.pdf
- [106] J. Hadamard, *Lectures on Cauchy's Problem in Linear Partial Differential Equations* (Yale U. Press, 1923), http://kirkmcd.princeton.edu/examples/mechanics/hadamard_lectures_23.pdf
- [107] O. Klein, *Die Reflexion von Elektronen an einem Potentialsprung nach der relativistischen Dynamik von Dirac*, Z. Phys. **53**, 157 (1929),
http://kirkmcd.princeton.edu/examples/QED/klein_zp_53_157_29.pdf
- [108] F. Sauter, *Über das Verhalten eines Elektrons im homogenen elektrischen Feld nach der relativistischen Theorie Diracs*, Z. Phys. **69**, 742 (1931),
http://kirkmcd.princeton.edu/examples/QED/sauter_zp_69_742_31.pdf
Zum 'Kleinschen Paradoxon', Z. Phys. **73**, 547 (1931),
http://kirkmcd.princeton.edu/examples/QED/sauter_zp_73_547_31.pdf
- [109] G. Wentzel, *Über die Eigenkräfte der Elementarteilchen*, Z. Phys. **86**, 479, 635 (1933);
87, 726 (1934), http://kirkmcd.princeton.edu/examples/EM/wentzel_zp_86_479_33.pdf
- [110] V. Weisskopf, *Probleme der neueren Quantentheorie des Elektrons*, Naturw. **23**, 631 (1935), kirkmcd.princeton.edu/examples/QED/weisskopf_naturw_23_631_35.pdf
- [111] P.A.M. Dirac, *Classical Theory of Radiating Electrons*, Proc. Roy. Soc. A **167**, 148 (1938), http://kirkmcd.princeton.edu/examples/EM/dirac_prsla_167_148_38.pdf
- [112] P.A.M. Dirac, *La théorie de l'électron et du champ électromagnétique*, Ann. Inst. H. Poincaré **9**, 13 (1939), http://kirkmcd.princeton.edu/examples/EM/dirac_ahp_9_13_39.pdf
- [113] S.A. Schelkunoff, *Theory of Antennas of Arbitrary Shape and Size*, Proc. I.R.E. **29**, 493 (1941), http://kirkmcd.princeton.edu/examples/EM/schelkunoff_pire_29_493_41.pdf
- [114] P.A.M. Dirac, *The physical interpretation of quantum mechanics*, Proc. Roy. Soc. A **180**, 1 (1942), http://kirkmcd.princeton.edu/examples/QED/dirac_prsla_180_1_42.pdf
- [115] C.J. Eliezer, *On the classical theory of particles*, Proc. Roy. Soc. A **194**, 543 (1948),
http://kirkmcd.princeton.edu/examples/EM/eliezer_prsla_194_543_48.pdf
- [116] T.A. Welton, *Some Observable Effects of the Quantum-Mechanical Fluctuations of the Electromagnetic Field*, Phys. Rev. **75**, 1157 (1948),
kirkmcd.princeton.edu/examples/QED/welton_pr_74_1157_48.pdf
- [117] R.V. Jones, *Pressure or Radiation*, Nature **171**, 1089 (1953),
http://kirkmcd.princeton.edu/examples/EM/jones_nature_171_1089_53.pdf

- [118] H. Bondi and T. Gold, *The field of a uniformly accelerated charge, with special reference to the problem of gravitational acceleration*, Proc. Roy. Soc. (London) A **229**, 416 (1955), http://kirkmcd.princeton.edu/examples/EM/bondi_prsla_229_416_55.pdf
- [119] B.D. Mills, Jr, *Satellite Paradox*, Am. J. Phys. **27**, 115 (1959), http://kirkmcd.princeton.edu/examples/mechanics/mills_ajp_27_115_59.pdf
- [120] A. Schild, *On the Radiation Emitted by an Accelerated Point Charge*, J. Math. Anal. App. **1**, 127 (1960), http://kirkmcd.princeton.edu/examples/EM/schild_jmma_1_127_60.pdf
- [121] T. Fulton and F. Rohrlich, *Classical Radiation from a Uniformly Accelerated Charge*, Ann. Phys. **9**, 499 (1960), http://kirkmcd.princeton.edu/examples/EM/fulton_ap_9_499_60.pdf
- [122] F. Rohrlich, *The Equations of Motions of Classical Charges*, Ann. Phys. **13**, 93 (1961), http://kirkmcd.princeton.edu/examples/EM/rohrlich_ap_13_93_61.pdf
- [123] F. Rohrlich, *The Definition of Electromagnetic Radiation*, Nuovo Cim. **21**, 811 (1961), http://kirkmcd.princeton.edu/examples/EM/rohrlich_nc_21_811_61.pdf
- [124] S. Coleman, *Classical Electron Theory from a Modern Standpoint*, RM2829 (Rand Co., Sept. 1961), http://kirkmcd.princeton.edu/examples/EM/coleman_RM2820_61.pdf reprinted in *Paths to Research*, D. Teplitz, ed. (Plenum, New York, 1982), p. 183, http://kirkmcd.princeton.edu/examples/EM/coleman_epr_183_82.pdf
- [125] W.K.H. Panofsky and M. Phillips, *Classical Electricity and Magnetism*, 2nd ed. (Addison-Wesley, 1962), <http://kirkmcd.princeton.edu/examples/EM/panofsky-phillips.pdf>
- [126] R. Becker, *Electromagnetic Fields and Interactions* (Dover, 1964), http://kirkmcd.princeton.edu/examples/EM/becker_64_EIV.pdf
- [127] A.E. Woodruff, *William Crookes and the Radiometer*, Isis **57**, 188 (1966), http://kirkmcd.princeton.edu/examples/EM/woodruff_isis_57_188_66.pdf
- [128] T. Hirose, *Origins of Lorentz' Theory of Electrons and the Concept of the Electromagnetic Field*, Hist. Stud. Phys. Sci. **1**, 151 (1969), http://kirkmcd.princeton.edu/examples/EM/hirosige_hsps_1_151_69.pdf
- [129] V.L. Ginzburg, *Radiation and Radiation Friction Force in Uniformly Accelerated Motion*, Sov. Phys. Uspekhi **12**, 565 (1970), http://kirkmcd.princeton.edu/examples/EM/ginzburg_spu_12_565_70.pdf
- [130] S. Goldberg, *The Abraham Theory of the Electron: The Symbiosis of Experiment and Theory*, Arch. Hist. Exact Sci. **7**, 7 (1970), http://kirkmcd.princeton.edu/examples/EM/goldberg_ahes_7_7_70.pdf
- [131] C. Teitelboim, *Splitting of the Maxwell Tensor: Radiation Reaction without Advanced Fields*, Phys. Rev. D **1**, 1572 (1970), http://kirkmcd.princeton.edu/examples/EM/teitelboim_prd_1_1572_70.pdf
Splitting of the Maxwell Tensor, II. Sources, Phys. Rev. D **3**, 297 (1971), http://kirkmcd.princeton.edu/examples/EM/teitelboim_prd_3_297_71.pdf

- [132] C. Teitelboim and C.A. López, *Remarks on the Classical Electron*, Lett. Nuovo Cim. **2**, 225 (1971), http://kirkmcd.princeton.edu/examples/EM/teitelboim_lnc_2_225_71.pdf
- [133] L. Mandel, *Energy Flow from an Atomic Dipole in Classical Electrodynamics*, J. Opt. Soc. Am. **62**, 1011 (1972),
http://kirkmcd.princeton.edu/examples/EM/mandel_josa_62_1011_72.pdf
- [134] A.I. Miller, *A Study of Henri Poincaré's "Sur la Dynamique de l'Électron"*, Arch. Hist. Exact Sci. **10**, 207 (1973),
http://kirkmcd.princeton.edu/examples/GR/miller_ahes_10_207_73.pdf
- [135] J.R. Ackerhalt, P.L. Knight and J.H. Eberly, *Radiation Reaction and Radiative Frequency Shifts*, Phys. Rev. Lett. **30**, 456 (1973),
kirkmcd.princeton.edu/examples/QED/ackerhalt_prl_30_456_73.pdf
- [136] I.R. Senitzky, *Radiation-Reaction and Vacuum-Field Effects in Heisenberg-Picture Quantum Electrodynamics*, Phys. Rev. Lett. **31**, 955 (1973),
kirkmcd.princeton.edu/examples/QED/senitzky_prl_31_955_73.pdf
- [137] P.W. Milonni, J.R. Ackerhalt and W.A. Smith, *Interpretation of Radiative Corrections in Spontaneous Emission*, Phys. Rev. Lett. **31**, 958 (1973),
kirkmcd.princeton.edu/examples/QED/milonni_prl_31_958_73.pdf
- [138] E.J. Moniz and D.H. Sharp, *Absence of runaways and divergent self-mass in non-relativistic quantum electrodynamics* *Radiation Reaction in Electrodynamics and the Elimination of Runaway Solutions*, Phys. Rev. D **10**, 1133 (1974),
http://kirkmcd.princeton.edu/examples/EM/moniz_prd_10_1133_74.pdf
- [139] S.W. Hawking, *Black Hole Explosions*, Nature **248**, 30 (1974),
http://physics.princeton.edu/~mcdonald/examples/QED/hawking_nature_248_30_74.pdf
Particle Creation by Black Holes, Comm. Math. Phys. **43**, 199 (1975),
http://physics.princeton.edu/~mcdonald/examples/QED/hawking_cmp_43_199_75.pdf
- [140] J.R. Ackerhalt and J.H. Eberly, *Quantum electrodynamics and radiation reaction: Nonrelativistic atomic frequency shifts and lifetimes*, Phys. Rev. D **10**, 3350 (1974),
http://kirkmcd.princeton.edu/examples/QED/ackerhalt_prd_10_3350_74.pdf
- [141] P.W. Milonni and W.A. Smith, *Radiation reaction and vacuum fluctuations in spontaneous emission*, Phys. Rev. A **11**, 814 (1975),
kirkmcd.princeton.edu/examples/QED/milonni_pra_11_814_75.pdf
- [142] A.N. Gordeyev, *A simultaneous expansion for the electromagnetic field of a relativistic charged particle*, J. Phys. A **8**, 1048 (1975),
http://kirkmcd.princeton.edu/examples/EM/gordeyev_jpa_8_1048_75.pdf
- [143] L.D. Landau and E.M. Lifshitz, *The Classical Theory of Fields*, 4th ed. (Pergamon Press, 1975), http://kirkmcd.princeton.edu/examples/EM/landau_ctf_71.pdf
The first Russian edition appeared in 1941, and the second in 1948,

- http://kirkmcd.princeton.edu/examples/EM/landau_teorja_polya_41.pdf
http://kirkmcd.princeton.edu/examples/EM/landau_teorja_polya_48_p235.pdf
- [144] P.W. Milonni, *Semiclassical and quantum-electrodynamical approaches in nonrelativistic radiation theory*, Phys. Rep. **25**, 1 (1976),
http://kirkmcd.princeton.edu/examples/QED/milonni_pr_25_1_76.pdf
- [145] W.G. Unruh, *Notes on Black Hole Evaporation*, Phys. Rev. D **14**, 870 (1976),
http://physics.princeton.edu/~mcdonald/examples/QED/unruh_prd_14_870_76.pdf
Particle Detectors and Black Hole Evaporation, Ann. N.Y. Acad. Sci. **302**, 186 (1977),
http://physics.princeton.edu/~mcdonald/examples/QED/unruh_anyas_302_186_77.pdf
- [146] H. Levine, E.J. Moniz and D.H. Sharp, *Motion of Extended Charges in Classical Electrodynamics*, Am. J. Phys. **45**, 75 (1977),
http://kirkmcd.princeton.edu/examples/EM/levine_ajp_45_75_77.pdf
- [147] D.J. Griffiths and E.W. Szeto, *Dumbbell Model for the Classical Radiation Reaction*, Am. J. Phys. **46**, 244 (1978), http://kirkmcd.princeton.edu/examples/EM/griffiths_ajp_46_244_78.pdf
- [148] K.T. McDonald, *Radiated Power Distribution in the Far Zone of a Moving System* (Apr. 24, 1979), http://kirkmcd.princeton.edu/examples/moving_far.pdf
- [149] K.T. McDonald, *The Force on an Antenna Array* (May 1, 1979),
http://kirkmcd.princeton.edu/examples/antenna_force.pdf
- [150] D.G. Boulware, *Radiation from a Uniformly Accelerated Charge*, Ann. Phys. **124**, 169 (1980), http://kirkmcd.princeton.edu/examples/EM/boulware_ap_124_169_80.pdf
- [151] C. Teitelboim, D. Villarroel and C.G. van Weert, *Classical Electrodynamics of Retarded Fields and Point Particles*, Riv. Nuovo Cim. **3**(9), 1 (1980),
[http://kirkmcd.princeton.edu/examples/EM/teitelboim_rnc_3\(9\)_1_80.pdf](http://kirkmcd.princeton.edu/examples/EM/teitelboim_rnc_3(9)_1_80.pdf)
- [152] A. Rose, *Spontaneous Emission Revisited*, Phys. Stat. Sol. A **61**, 133 (1980),
kirkmcd.princeton.edu/examples/QED/rose_pssa_61_133_80.pdf
- [153] A.T. Young, *Rayleigh scattering*, Appl. Optics **20**, 533 (1981),
http://kirkmcd.princeton.edu/examples/EM/young_ao_20_533_81.pdf
- [154] A.I. Miller, *Albert Einstein's Special Theory of Relativity — Emergence (1905) and Early Interpretation (1905-1911)* (Addison-Wesley, 1981).
- [155] B. Fain, *Spontaneous Emission vs. Vacuum Fluctuations*, Nuovo Cim. B **68**, 73 (1982),
kirkmcd.princeton.edu/examples/QED/fain_nc_68b_73_82.pdf
- [156] M. Cray, M.L. Shih and P.W. Milonni, *Stimulated emission, absorption and interference*, Am. J. Phys. **50**, 1016 (1982),
kirkmcd.princeton.edu/examples/QED/cray_ajp_50_1016_82.pdf

- [157] J. Dalibard, J. Dupont-Roc and C. Cohen-Tannoudji, *Vacuum fluctuations and radiation reaction: identification of their respective contributions*, J. Phys. **43**, 1617 (1982), kirkmcd.princeton.edu/examples/QED/dalibard_jp_43_1617_82.pdf
- [158] P. Candelas and D.W. Sciama, *Is there a quantum equivalence principle?* Phys. Rev. D **27**, 1715 (1983), kirkmcd.princeton.edu/examples/QED/candelas_prd_27_1715_83.pdf
- [159] P.W. Milonni, *Why spontaneous emission?* Am. J. Phys. **52**, 340 (1984), kirkmcd.princeton.edu/examples/QED/milonni_ajp_52_340_84.pdf
- [160] J. Gea-Banacloche, M.O. Scully and M.S. Zubairy, *Vacuum Fluctuations and Spontaneous Emission in Quantum Optics*, Phys. Scr. **T21**, 81 (1988), kirkmcd.princeton.edu/examples/QED/gea-banacloche_ps_t21_81_88.pdf
- [161] P.W. Milonni, *Different Ways of Looking at the Electromagnetic Vacuum*, Phys. Scr. **T21**, 102 (1988), kirkmcd.princeton.edu/examples/QED/milonni_ps_t21_102_88.pdf
- [162] M.O. Scully, *The Role of Vacuum Fluctuations and Spontaneous Emission in the Laser Linewidth*, Phys. Scr. **T21**, 119 (1988), kirkmcd.princeton.edu/examples/QED/scully_ps_t21_119_88.pdf
- [163] L.B. Okun, *The Concept of Mass*, Phys. Today **42**, (6) 31 (1989), http://kirkmcd.princeton.edu/examples/mechanics/okun_pt_42_31_89.pdf
Formula $E = mc^2$ in the Year of Physics, Acta Phys. Pol. B **37**, 1327 (2006), http://kirkmcd.princeton.edu/examples/EM/okun_app_b37_1327_06.pdf
The Einstein formula: $E_0 = mc^2$. "Isn't the Lord laughing?" Phys. Usp. **51**, 513 (2008), http://kirkmcd.princeton.edu/examples/mechanics/okun_pu_51_513_08.pdf
Mass versus relativistic and rest masses, Am. J. Phys. **77**, 430 (2009), http://kirkmcd.princeton.edu/examples/mechanics/okun_ajp_77_430_09.pdf
- [164] N. Itoh, *Radiation reaction due to magnetic dipole radiation*, Phys. Rev. A **43**, 1002 (1991), http://kirkmcd.princeton.edu/examples/EM/itoh_pra_43_1002_91.pdf
- [165] G.W. Ford and R.F. O'Connell, *Radiation Reaction in Electrodynamics and the Elimination of Runaway Solutions*, Phys. Lett. A **157**, 217 (1991), http://kirkmcd.princeton.edu/examples/EM/ford_pl_a157_217_91.pdf
- [166] S.H. Schot, *Eighty Years of Sommerfeld's Radiation Condition*, Hist. Math. **19**, 385 (1992), http://kirkmcd.princeton.edu/examples/EM/schot_hm_19_385_92.pdf
- [167] H.G. Schantz, *The flow of electromagnetic energy in the decay of an electric dipole*, Am. J. Phys. **63**, 513 (1995), http://kirkmcd.princeton.edu/examples/EM/schantz_ajp_63_513_95.pdf
Electromagnetic Energy Around Hertzian Dipoles, IEEE Ant. Prop. Mag. **43**, 50 (2001), http://kirkmcd.princeton.edu/examples/EM/schantz_ieeeapm_43_50_01.pdf
- [168] K.T. McDonald, *Hawking-Unruh Radiation and Radiation of a Uniformly Accelerated Charge* (Feb. 3, 1998), <http://kirkmcd.princeton.edu/accel/unruh.pdf>

- [169] J.D. Jackson, *Classical Electrodynamics*, 3rd ed. (Wiley, 1999), http://kirkmcd.princeton.edu/examples/EM/jackson_ce3_99.pdf
- [170] F. Rohrlich, *The self-force and radiation reaction*, Am. J. Phys. **68**, 1109 (2000), http://kirkmcd.princeton.edu/examples/EM/rohrlich_ajp_68_1109_00.pdf
- [171] H. Spohn, *The critical manifold of the Lorentz-Dirac equation*, Europhys. Lett. **50**, 287 (2000), http://kirkmcd.princeton.edu/examples/EM/spohn_epl_50_287_00.pdf
- [172] E. Eriksen and Ø. Grøn, *Electrodynamics of Hyperbolically Accelerated Charges I. The Electromagnetic Field of a Charged Particle with Hyperbolic Motion*, Ann. Phys. **286**, 320 (2000), http://kirkmcd.princeton.edu/examples/EM/eriksen_ap_286_320_00.pdf
II. Does a Charged Particle with Hyperbolic Motion Radiate? Ann. Phys. **286**, 343 (2000), http://kirkmcd.princeton.edu/examples/EM/eriksen_ap_286_343_00.pdf
III. Energy-Momentum of the Field of a Hyperbolically Moving Charge, Ann. Phys. **286**, 373 (2000), http://kirkmcd.princeton.edu/examples/EM/eriksen_ap_286_373_00.pdf
IV. Energy-Momentum Conservation of Radiating Charged Particles Ann. Phys. **297**, 243 (2002), http://kirkmcd.princeton.edu/examples/EM/eriksen_ap_297_243_02.pdf
V. The field of a charge in the Rindler space and the Milne space, Ann. Phys. **313**, 147 (2004), http://kirkmcd.princeton.edu/examples/EM/eriksen_ap_313_147_04.pdf
- [173] M. Marino, *The unexpected flight of the electron in a classical hydrogen-like atom*, J. Phys. A **36**, 11247 (2003), http://kirkmcd.princeton.edu/examples/EM/marino_jpa_36_11247_03.pdf
- [174] H. Spohn, *Dynamics of Charged Particles and Their Radiation Field* (Cambridge U. Press, 2004).
- [175] C. de Almeida and A. Saa, *The radiation of a uniformly accelerated charge is beyond the horizon: A simple derivation*, Am. J. Phys. **74**, 154 (2006), http://kirkmcd.princeton.edu/examples/EM/almeida_ajp_74_154_06.pdf
- [176] K.T. McDonald, *The Radiation-Reaction Force and the Radiation Resistance of Small Antennas* (Jan. 21, 2006), <http://kirkmcd.princeton.edu/examples/resistance.pdf>
- [177] K.T. McDonald, *The Fields of a Pulsed, Small Dipole Antenna* (Mar. 16, 2007), http://kirkmcd.princeton.edu/examples/pulsed_dipole.pdf
- [178] F. Rohrlich, *Dynamics of a charged particle*, Phys. Rev. E **77**, 046609 (2008), http://kirkmcd.princeton.edu/examples/EM/rohrlich_pre_77_046609_08.pdf
- [179] Ø. Grøn, *The significance of the Schott energy for energy-momentum conservation of a radiating charge obeying the Lorentz-Abraham-Dirac equation*, Am. J. Phys. **79**, 115 (2011), http://kirkmcd.princeton.edu/examples/EM/gron_ajp_79_115_11.pdf
- [180] K.T. McDonald, *FitzGerald's Calculation of the Radiation of an Oscillating Magnetic Dipole* (June 20, 2010), <http://kirkmcd.princeton.edu/examples/fitzgerald.pdf>
- [181] K.T. McDonald, *On the Definition of Radiation by a System of Charges* (Sept. 6, 2010), <http://kirkmcd.princeton.edu/examples/radiation.pdf>

- [182] K.T. McDonald, *Radiation by a Time-Dependent Current Loop* (Sept. 26, 2010), <http://kirkmcd.princeton.edu/examples/currentloop.pdf>
- [183] N. Neitz and A. Di Piazza, *Stochasticity Effects in Quantum Radiation Reaction*, Phys. Rev. Lett. **111**, 054802 (2013), http://kirkmcd.princeton.edu/examples/QED/neitz_prl_111_054802_13.pdf
- [184] D.-C. Dai and D. Stojkovic, *Origin of the tail in Greens functions in odd dimensional space-times* (Oct. 30, 2013), http://kirkmcd.princeton.edu/examples/EM/dai_1309.2996.pdf
- [185] K.T. McDonald, *J.J. Thomson and “Hidden” Momentum* (Apr. 30, 2014), <http://kirkmcd.princeton.edu/examples/thomson.pdf>
- [186] P.W. Smorenburg, L.P.J. Kamp and O.J. Luiten, *Classical formulations of the electromagnetic self-force of extended charged bodies*, Eur. Phys. J. H **39**, 283 (2014), http://kirkmcd.princeton.edu/examples/EM/smorenburg_epjh_39_283_14.pdf
- [187] V. Onoouchin and K.T. McDonald, *Fields of a Uniformly Accelerated Charge* (Aug. 19, 2014), <http://kirkmcd.princeton.edu/examples/schott.pdf>
- [188] M. Badino, *The Bumpy Road: Max Planck from Radiation Theory to the Quantum (1896-1906)*, (Springer, 2015), http://kirkmcd.princeton.edu/examples/EM/badino_planck_15.pdf
- [189] A. Di Piazza, T.N. Wistisen and U.I. Uggerhøj, *Investigation of classical radiation reaction with aligned crystals*, Phys. Lett. B **765**, 1 (2017), http://kirkmcd.princeton.edu/examples/EM/dipiazza_pl_b765_1_17.pdf
- [190] C. Galeriu, *Electric charge in hyperbolic motion: the early history*, Arch. Hist. Exact Sci. **71**, 363 (2017), http://kirkmcd.princeton.edu/examples/EM/galeriu_ahes_71_363_17.pdf
- [191] K.T. McDonald, *The Radiation Reaction during the Collapse of a Classical Electric Dipole* (Aug. 24, 2017), <http://kirkmcd.princeton.edu/examples/collapse.pdf>
- [192] T.N. Wistisen, A. Di Piazza, H.V. Knudsen and U.I. Uggerhøj, *Experimental Evidence of Quantum Radiation Reaction in Aligned Crystals* Nature Comm. **9**, 795 (2018), http://kirkmcd.princeton.edu/examples/QED/wistisen_nc_9_795_18.pdf
- [193] J.M. Cole *et al.*, *Experimental Evidence of Radiation Reaction in the Collision of a High-Intensity Laser Pulse with a Laser-Wakefield Accelerated Electron Beam*, Phys. Rev. X **8**, 011020 (2018), http://kirkmcd.princeton.edu/examples/QED/cole_prx_8_011020_18.pdf
- [194] K. Brown, *Huygen’s Principle*, <https://www.mathpages.com/home/kmath242/kmath242.htm>
Spherical Waves in Higher Dimensions, <https://www.mathpages.com/home/kmath614/kmath614.htm>
Waves in Ascending and Descending Dimensions, <https://www.mathpages.com/home/kmath614/kmath617.htm>

- [195] K. Poder *et al.*, *Experimental Signatures of the Quantum Nature of Radiation Reaction in the Field of an Ultraintense Laser*, Phys. Rev. X **8**, 031004 (2018), http://kirkmcd.princeton.edu/examples/QED/poder_prx_8_031004_18.pdf
- [196] D. Boito *et al.*, *On Maxwell's electrodynamics in two spatial dimensions* (Sept. 20, 2018), <https://arxiv.org/abs/1809.07368>
- [197] V. Hnizdo and G. Vaman, *Electromagnetic self-force of a point charge from the rate of change of the momentum of its retarded self-field*, Rep. Mod. Phys. **84**, 61 (2019), http://kirkmcd.princeton.edu/examples/EM/hnizdo_rmp_84_61_19.pdf
- [198] B.P. Kosyakov, *Self-interaction in classical gauge theories and gravitation*, Phys. Rep. **812**, 1 (2019), http://kirkmcd.princeton.edu/examples/EM/kosyakov_pr_812_1_19.pdf
- [199] A. Fedotov *et al.*, *Advances in QED with intense background fields* (Feb. 28, 2022), <https://arxiv.org/abs/2203.00019>
- [200] A. Gonsokov *et al.*, *Charged particle motion and radiation in strong electromagnetic fields* (Mar. 22, 2022), <https://arxiv.org/abs/2107.02161>